

2500 Automatic Tank Gauge

Mechanically operated, float and tape gauges for continuous liquid-level measurement in bulk storage tanks

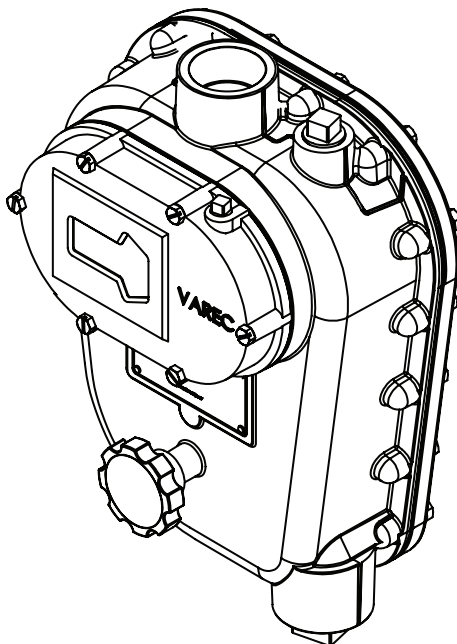

Copyright

© 2023, All rights reserved. Printed in the United States of America.

Except as permitted under the United States Copyright Act of 1976, no part of this publication may be reproduced, stored in a retrieval system or transmitted in any form or by any means – electronic, mechanical, photocopying, recording, or otherwise – without the prior written permission of the Publisher:

Varec, Inc.
5834 Peachtree Corners East
Peachtree Corners, Georgia 30092
Phone: (770) 447–9202
Fax: (770) 662–8939

Trademarks Acknowledged

Varec, Inc. recognizes all other trademarks. Trademarks of other products mentioned in this manual are held by the companies producing them.

FuelsManager®, TankView®, and, Varec® are registered trademarks of Varec, Inc.

All other product and service names mentioned are the trademarks of their respective companies.

Documentation Control

This document and the information provided within are controlled by the approvals agency(s) listed below. All changes to this document must be submitted to and approved by the agency(s) before public release.

- FM Approvals (FM)
- ATEX
- IECEx
- UKCA

FCC (US)

This device complies with Part 18 of the FCC Rules.

Operation is subject to the following two conditions:

1. This device may not cause harmful interference.
2. This device must accept any interference received, including interference that may cause undesired operation.

Note This equipment has been tested and found to comply with the limits for a Class A digital device, pursuant to Part 18 of the FCC Rules. These limits are designed to provide reasonable protection against harmful interference when the equipment is operated in a commercial environment. Any modifications made to this device that are not approved by Varec, Inc. may void the user's authority to operate this equipment.

ICES-003 Class A Notice

This Class A digital apparatus complies with Canadian ICES-003.

Cet appareil numérique de la classe A est conforme à la norme NMB-003 du Canada

Disclaimer of Warranties

The contract between the Seller and the Buyer states the entire obligation of the Seller. The contents of this instruction manual shall not become part of or modify any prior or existing agreement, commitment, or relationship between the Seller and Buyer. There are no express or implied warranties set out in this instruction manual. The only warranties that apply are those in the existing contract between the Seller and Buyer.

The 2500 Automatic Tank Gauge (LPT) has not been tested by Varec under all possible operational conditions, and Varec may not have all the data relative to your application. The information in this instruction manual is not all inclusive and does not and cannot take into account all unique situations. Consequently, the user should review this product literature in view of his or her application. If you have any further questions, please contact Varec for assistance.

Limitations of Seller's Liability

In the event that a court holds that this instruction manual created some new warranties, Seller's liability shall be limited to repair or replacement under the standard warranty clause. In no case shall the Seller's liability exceed that stated as Limitations of Remedy in the contract between the Seller and Buyer.

Use of parts that are not manufactured or supplied by Varec voids any warranty and relieves Varec of any obligation to service the product under warranty. Varec recommends the use of only Varec manufactured or supplied parts to maintain or service Varec 2500 Automatic Tank Gauges.

Terms of Use

The information provided in this document is provided "as is" without warranty of any kind. Varec, Inc. disclaim all warranties, either express or implied, including the warranties of merchantability and fitness for a particular purpose. In no event shall Varec, Inc. or its suppliers be liable for any damages whatsoever including direct, indirect, incidental, consequential, loss of business profits or special damages, even if Varec, Inc. or its suppliers have been advised of the possibility of such damages.

This manual is solely intended to describe product installation, operation, calibration, and maintenance and should not be used for any other purpose. It is subject to change without prior notice. This manual was prepared with the highest degree of care. However, should you find any errors or have any questions, contact one of our service offices or your local sales agent.

Safety Precaution Definitions

Caution! Damage to equipment may result if this precaution is disregarded.

Warning! Direct injury to personnel or damage to equipment which can cause injury to personnel may result if this precaution is not followed.

Note Qualified personnel are required for installation of this product in a hazardous environment.

Safety Precautions

Read this manual carefully and make sure you understand its contents before using this product. Follow all instructions and safety guidelines presented in this manual when using this product. If the user does not follow these instructions properly, Varec cannot guarantee the safety of the system.

Note Comply with all applicable regulations, codes, and standards. For safety precautions, the user should refer to the appropriate industry or military standards.

Caution! Electrical Hazard! Read and understand static and lightning electrical protection and grounding described in API 2003. Make certain that the tank installation, operation, and maintenance conforms with the practice set forth therein.

Warning! Striking the gaugehead or the transmitter with a metal object could cause a spark to occur. When removing or replacing the gaugehead in flammable or hazardous liquid storage areas, take necessary measures to protect the gaugehead from impact.

Warning! Volatile fumes may be present! Ensure that the tank has been leak and pressure tested as appropriate for the liquid to be stored. Observe appropriate safety precautions in flammable or hazardous liquid storage areas. Do not enter a tank that has contained hydrocarbons, vapors, or toxic materials, until a gas-free environment is certified. Carry breathing equipment when entering a tank where oxygen may be displaced by carbon dioxide, nitrogen, or other gases. Wear safety glasses as appropriate. Use a hard hat.

Warning! Sparks or static charge could cause fire or explosion! The mechanical connections between the guide cables, the float, the tape, and the gaugehead provide conductivity to ground that is adequate for the safe electrical drain of electrostatic charges that may accumulate in the tank and the product. Worker activity and worker clothing may accumulate electrostatic charges on the body of a worker. Care should be used in flammable environments to avoid the hazard.

Warning! Potential static hazard! The polyester labels may hold static charge and user needs to mitigate risk before handling.

| | | |
|----------|--|----|
| 1 | Introduction | 13 |
| | Using this Manual | 13 |
| | Getting Acquainted with the 2500 Automatic Tank Gauge Systems | 14 |
| | Tank Gauge Operation | 15 |
| | Calibration and Volume Measurement | 15 |
| | System Integration | 16 |
| | Product Options | 16 |
| | English and Metric Configurations | 16 |
| | Check Knob | 17 |
| | Negator Cassette | 17 |
| | Float Crank | 17 |
| 2 | General Preparation | 19 |
| | Safety Precautions | 19 |
| | Tools, Equipment, and Materials | 19 |
| | Guidelines, Recommendations, and Options When Preparing for Installation | 20 |
| | Floating Roof Tank Installations | 20 |
| | Guide Wires and Anchors | 21 |
| | Support Brackets | 22 |
| | Conduit (Pipework) and Couplings | 22 |
| | Tank Roof Entry via Manhole & Inspection Covers | 23 |
| | Floats | 24 |
| | Identifying Your Installation Type | 24 |
| | Cone Roof Tank | 24 |
| | Bolted Tank | 25 |
| | Cone Roof Tank with Internal (Floating Roof) Pan and Floatwell | 26 |
| | Cone Roof Tank and Internal (Floating Roof) Pan: No Floatwell | 27 |
| | Tank Top Mounting | 28 |
| | Stilling Well Service Cone Roof Tank 6" Diameter Float | 29 |
| | External Floating Roof Tank and Floatwell | 30 |
| | External Floating Roof Tank: No Floatwell | 31 |
| | Interface Service | 32 |
| 3 | Installation | 35 |
| | Installation Schematics | 35 |
| | Tank Roof Entry - Cone Roof Tank | 38 |
| | Tank Roof Entry - Internal Pan (Floating Roof) | 39 |
| | Tank Roof Entry - Stilling Well | 40 |
| | Correct Float Positioning for an External Floating Pan Installation | 40 |
| | Installing Anchors and Guide Wires | 41 |
| | Installing Support Brackets & Pipework | 42 |
| | Installing a Gauge Head at Grade Level | 43 |

| | |
|--|-----------|
| Installing a Roof Reading Gauge Head | 44 |
| Float installation on an Out-of-Service Tank | 44 |
| Cone Roof Tank | 44 |
| Floating Pan with Floatwell. | 45 |
| Connecting the Tape to the Float. | 45 |
| Connecting the Cable to a Float in a Floatwell. | 46 |
| Connecting the Cable to a Floating Pan. | 47 |
| Connecting the Tape to a 6" Interface Float in an 8" Stilling Well | 48 |
| Feeding the Tape to a Gauge Head Located at Grade Level | 49 |
| Install Tape in the Gauge Head | 50 |
| With a Negator Spring Motor | 51 |
| With a Negator Cassette | 52 |
| With a Hand Crank Gauge Head. | 54 |
| Trimming the Cable at the Float in a Floatwell | 55 |
| Reset the Counter | 55 |
| Reading the Counter | 56 |
| Setting Counter Spacing | 57 |
| Calibrate the Counter | 60 |
| Install a Transmitter and Replace all Covers | 62 |
| Initial Operation | 63 |
| 4 In-Service Installation Procedures | 67 |
| Negator Cassette Installation | 68 |
| Disassembly. | 69 |
| Assembly. | 69 |
| Oil Seal Installation. | 71 |
| 27-inch Water column operating pressure oil seal. | 72 |
| 8.5-inch Water Column Operating Pressure Oil Seal. | 73 |
| Inspection Hatch and Manhole Cover | 74 |
| Inspection Hatch | 74 |
| Manhole Cover | 74 |
| Guide Wire Bottom Anchors. | 75 |
| In-service Float & Guide Wire Installation | 75 |
| 5 Operation | 79 |
| 6 Gauge Head Disassembly and Re-assembly | 81 |
| Gauge Head Disassembly | 81 |
| Gauge Head Assembly | 85 |
| Counter Wheel Assembly. | 87 |

| | |
|---|------------|
| Counter Bearing Adjustment Procedure | 89 |
| 7 Maintenance Routines | 91 |
| Operation Check | 92 |
| Leak Check | 92 |
| Sediment Check | 93 |
| Deformation Check | 93 |
| Calibration Check | 93 |
| Float and Guide Wires Check | 93 |
| Lubrication and Oil Warnings | 93 |
| Corrosion Check | 94 |
| Basic Maintenance | 94 |
| Extended Maintenance | 94 |
| Overhaul / Maintenance | 94 |
| General Inspection | 95 |
| 8 Spare Parts and Maintenance Kits | 97 |
| Gauge Head Spare Parts | 98 |
| 2500 Cast Iron Gaugehead Spare Parts | 105 |
| Basic Maintenance Kit | 107 |
| Extended Maintenance Kit | 109 |
| Additional items | 111 |
| Overhaul/Refurbishing Kit | 112 |
| Additional items | 116 |
| Shoulder Bushing Retrofit Kit | 116 |
| Elbow Maintenance Kits | 118 |
| Negator Cassette and Negator Cassette Kit | 119 |
| Float Grounding Kit | 120 |
| Other Accessories | 121 |
| Condensate Reservoir | 121 |
| Shock Absorber | 121 |
| Floating Roof Anchor Weight | 122 |
| Part Numbers for Complete Gauge Heads Spare Parts | 122 |
| 9 Troubleshooting | 123 |
| Dials Do Not Respond When Gauge Check Knob is Rotated | 123 |
| Calibration Repeatability Unstable | 124 |

10 Specifications and Reference Data 127

Device Designation/Nameplate 127

CE Marks, Declaration of Conformity 127

2500 ATG Gauge Head 128

2500 ATG Product Dimensions 129

Floats 130

Conduit Elbows 131

Standard Installation Kits 131

Oil Seals 132

Approvals 132

Other Specifications 133

11 Order Codes 135

Aluminum Gauge Head – English Configuration – Negator Motor 135

Aluminum Gauge Head – Metric Configuration – Negator Motor 136

Aluminum Gauge Head – English Configuration – Float Crank 136

Aluminum Gauge Head – Metric Configuration – Float Crank 136

Iron Gauge Head – English Configuration 137

Iron Gauge Head – Metric Configuration 137

Aluminum Gauge Head – English Configuration – Negator Cassette 137

Aluminum Gauge Head – Metric Configuration – Negator Cassette 138

Change History

| Revision # | Minor Rev. | Date | Author | Approved By | Description of Change |
|------------|------------|------------|------------------|-------------|---|
| A | | 6/14/2021 | J. M. Rollins | | Initial Change History table addition |
| B | | 2/7/2022 | J. M. Rollins | J.Kolb | Updated the approval label |
| C | | 5/17/2022 | J. M. Rollins | T. Gibson | Updated select gauge head drawings and removal of unnecessary lubrication information |
| D | | 10/11/2022 | J.M. Rollins | T. Gibson | Added the Tape Storage Sheave Assembly as part of the Overhaul/Refurbishing Kit |
| E | | 10/26/2022 | J.M. Rollins | T. Gibson | Updated the crank handle assy info |
| F | | 11/2/2022 | J.M. Rollins | T. Gibson | Added step about venting gauge |
| G | | 12/13/2022 | J.M. Rollins | T. Gibson | Updated an electrostatic warning and addressed drilling of holes in the conduit |
| H | | 1/26/2023 | J.M. Rollins | T. Gibson | Updated the label and approvals info, corrected a warning, and removed Carp 20 references |
| I | | 11/30/2023 | Charlyn Lez Moss | Todd Gibson | Added electrostatic warning and updated nameplate, updated cover page and formats |

1 Introduction

Using this Manual

This manual is designed to assist the user in the installation, operation, maintenance, and troubleshooting of low-pressure 2500 Automatic Tank Gauges. Former 2600 Series gauges with a hand crank are included. These gauges are for use at atmospheric pressure or at low pressure (2.5 psig, 0.17 bar(g)). Medium- and high-pressure tanks are served by the 2520 ATG gauges for pressure vessels to 300 psig and are covered in their respective product manuals.

Proper operation of the gauge requires the user to pay serious attention to assuring high quality control during the installation. Long term, satisfactory performance of the gauge can thus be obtained. If the installation quality is compromised, gauge accuracy, and life may be degraded.

Getting Acquainted with the 2500 Automatic Tank Gauge Systems

The 2500 series of Automatic Tank Gauges (ATG) are float and tape operated instruments designed to provide continuous liquid-level measurement in bulk storage applications.

The gauge can be installed on the tank roof or at the tank side (at grade), which would facilitate ground level reading by the operator and is available with a wide variety of accessories for virtually every tank gauging application.

The level measurement is displayed using a dial and counter built into the gauge head. If electronic transmission of level data or temperature measurement integration is required in the control room, the gauge can be fitted with an optional tank gauging transmitter.

Figure 1-1: Typical 2500 ATG Installation

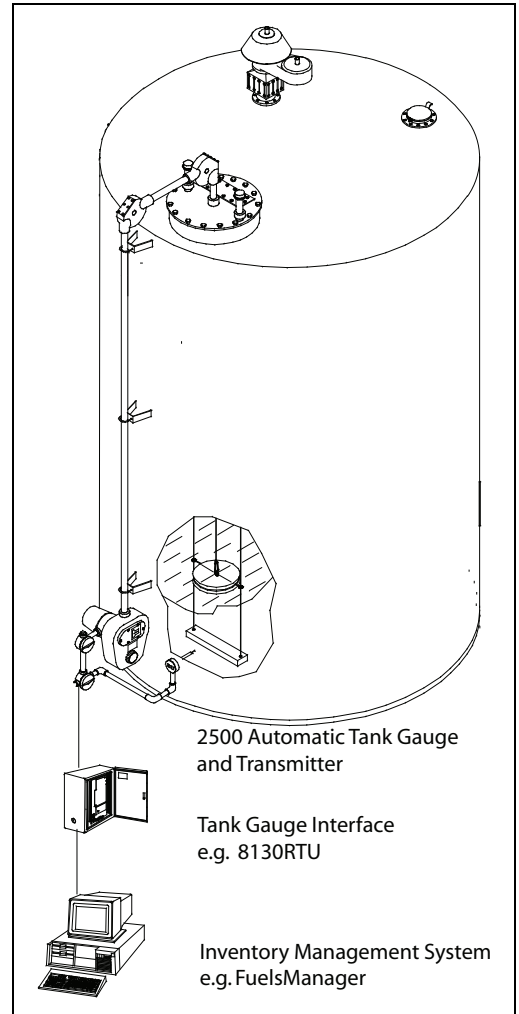

Tank Gauge Operation

The 2500 ATG uses a large, stainless steel float attached to a stainless steel perforated tape to detect the liquid level. The float follows the liquid level as it rises and falls due to the tension provided by a powerful negator spring or cartridge motor. The precisely perforated tape engages pins on a sprocket wheel that in turn drive the counter assembly. This simple design and operation allows the gauge to perform with negligible maintenance throughout its working life. (In some systems, the roof of the tank serves as the float — Varec does not recommend this.)

Figure 1-2: 2500 ATG Powered by Negator Motor No Electricity Required

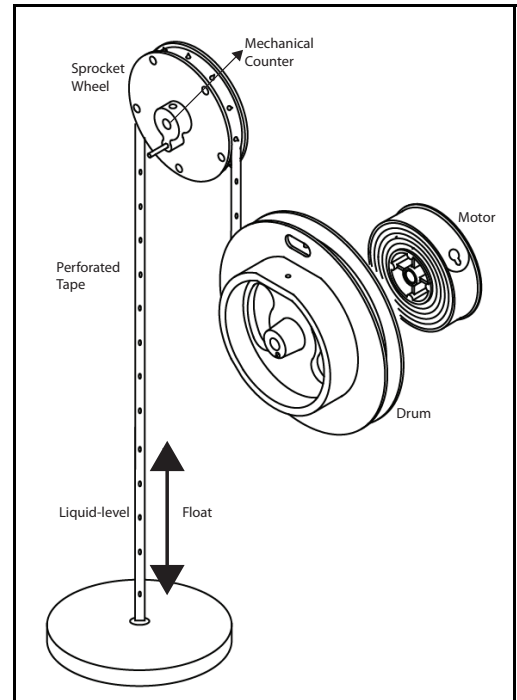

Calibration and Volume Measurement

Tank gauging measurements provide appropriate inventory checks and a valuable method of checking marine receipts and metered custody transfers. Accuracy of measurements requires that a number of factors be considered:

- Density and specific gravity of product as determined from representative samples
- Sediment in the tank
- Water content in the product
- Gross volume
- Temperature of the product
- Tank-bottom deformation

It is the user's responsibility to appropriately consider these and other factors in this application. For example, oil tank capacity tables are calculated for product at 60°F (15.6°C). A higher temperature will cause the tank to expand, and the actual volume will be greater than the volume at the standard temperature

| API Standard | Description |
|--|---|
| 2550 | Method For Measurement And Calibration Of Upright Cylindrical Tanks (ANSI/ASTM D1220) |
| 2545 | Method of Gauging Petroleum and Petroleum Products (ANSI/ASTM D1085) |
| 2540 | Chapter 11.1 (ANSI/ASTM D1250) for Volume Correction Factors. Refer also to API 2545. |
| Manual of Petroleum Measurement Standards, Chapter 3 – Tank Gauging, Section 1B, Standard Practice for Level Measurement of Liquid Hydrocarbons in Stationary Tanks by Automatic Tank Gauging. | |

Table 1-1: Calibration and Volume Measurement

System Integration

A range of analog and digital tank gauge transmitters is available that mounts directly to mechanical tank gauges.

Figure 1-3: 2500 ATG with a 2920 Float & Tape Transmitter

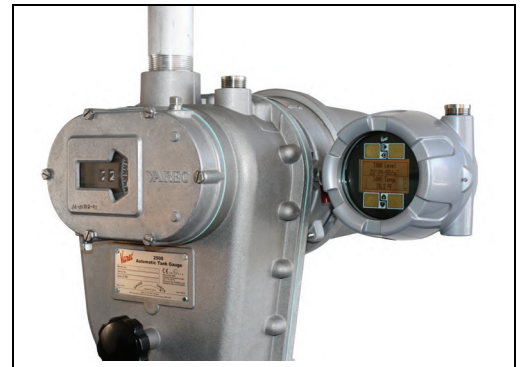

Level measurement data is encoded by the transmitter and output via industry standard communications to the control room. Some transmitters also offer spot temperature measurement integration that can be used for inventory control applications. When a tank gauge transmitter is used, communications and power are required at the gaugehead. Varec transmitters do not require an adaptor flange. When connecting third-party equipment, a specific adaptor flange, depending on the transmitter, is often required.

Product Options

English and Metric Configurations

Varec provides the following three measurement and display configurations:

- English fractional – feet/inches/16ths
- English decimal – feet/inches/10ths
- Metric configurations – meters/10ths/100ths

English reading gauges are manufactured with a reversible fractional/decimal dial. For example, if the customer desires a decimal level display, the dial can be removed,

reversed and reinstalled to show decimal units. All dial/counters reflect product innage. For outage reading requirements, Varec offers a conversion kit (Part #13-08774) for English units of measure only. Consult Varec if metric outage is required.

Check Knob

An operation checker, provided as a standard feature on both the 2500 and 2520 ATG, permits your technician to check the instrument for correct operation.

Caution! Do not attempt to operate the check knob if the tape/cable is attached directly to a floating roof to prevent damaging or breaking the tape.

Negator Cassette

The negator cassette improves the performance of your mechanical tank gauge by self-aligning the tape and motor as it provides the constant pullback tension required for the float to follow the liquid level. The cassette increases reliability and reduces maintenance by protecting internal moving parts from pipe debris that could cause stretching or corrosion. It also allows for safer, easier, and quicker service because there is no tape to pull out or negator hubs to unwind in your hands.

Float Crank

The float crank allows your operators to manually raise and lower the float. This can be useful during turbulent mixing conditions so that the float or tape is not damaged.

2 General Preparation

Safety Precautions

Before installing your 2500 ATG, read and review the see the “Safety Precautions” section of the preface to this document. Continuing with the installation according to the instructions in this manual presumes you have reviewed these safety precautions.

The instructions to install the perforated tape in the gauge head vary depending on the type of tape winding mechanism in your gauge head. The instructions for each of these methods follow the basic 2500 ATG system installation instructions. They include:

- Negator Spring Motor
- Negator Cassette
- Hand Crank

This manual does not cover all possible installations. Contact Varec if you need additional support or information for your installation.

Tools, Equipment, and Materials

User responsibilities include provision of the following items:

- 1.5-inch (DN40) conduit that carries the perforated tape
- Necessary mounting and support pipe and welding
- Drilling of any holes in the tank as needed
- Drilling of any holes in the conduit to vent vapors that may be present
- Assembling the necessary tools and equipment at the work site

Table 2-1 lists typical tools and equipment that may be needed. Use a drop cloth to maintain tool, equipment and installation kit cleanliness.

| Tools, Equipment, and Materials | | | |
|---------------------------------|--------------|-----------------------|------------------------|
| tape measure - long | string | level | Pipe taps & dies |
| cable cutter | chalk & line | vice | light oil |
| pipe cutter | compass | protractor | Dow Corning 4 compound |
| sheet metal shears | plumb bob | Electric drill & bits | Dow Corning RTV 737 |
| hole cutters | screwdrivers | tank hand gauge | Loctite 567 |
| pick | pliers | Welding equipment | Loctite 262 |
| shovel | wrenches | clean drop cloth | |

Table 2-1: User-Supplied Typical Tools and Equipment

Guidelines, Recommendations, and Options When Preparing for Installation

Various installation options and accessories are available to suit the user installation requirements. This section provides an overview and basic recommendations for elements of a 2500 ATG installation.

It is paramount that the user monitor the quality of the installation to assure long-term, accurate performance. All parts of the gauge head, tape, and float should move freely to reduce wear and maintenance. If the quality is compromised, an inferior operation may result. How a guide wire is anchored at the tank bottom and welding parts to or in the tank are major considerations. These additional items are also critical to a successful installation and operation of the 2500 ATG:

- Accurate hand gauging referenced to the tank bench mark
- Clean interior of the gauge piping
- No kinks in the tape or tape cable
- No noticeable binding friction in the mechanism
- Installation cleanliness
- True vertical gauge piping
- Location of float away from inlet pipes of mixers

Note Varec service contracts provide the user substantial savings for maintaining and refurbishing the systems already in service.

Floating Roof Tank Installations

Warning! Varec recommends that gauges be installed in a floatwell, rather than attaching the tape directly to the tank roof.

The floatwell should contain a baffle to prevent the float from escaping while allowing sufficient product movement to equalize the liquid level. No tape should be exposed outside of the roof or pipework. If any section of the tape is currently exposed, it should be replaced with a stainless steel, flexible cable. This will reduce measurement error due to wind drift. The connector between the tape and cable should not run over a conduit elbow (or pulley).

Note An internal floating roof is often referred to as a “Pan”, e.g. a cone roof tank with a pan and floatwell.

Varec offers a kit with a weight that sits on top of the floating roof rather than attaching directly to the roof. This protects the tape or cable from breaking.

Warning! Floating roof must be reinforced below the weight.

Guide Wires and Anchors

Note Varec recommends guide wire installations or stilling well installations where possible.

Varec recommends guide wire installations for the 2500 ATG with standard guide wire centers of 17" (432 mm) when a standard 14.5" (368 mm) diameter (Type 316 stainless steel hollow shell) float is used. Guide Wires provide stability for the float during turbulent conditions and provide increased accuracy by reducing the horizontal movement of the float across the surface of the product. The guide wires should be installed centered and free of twists or kinks. Check the movement of the float for friction or impeded movement before final operation.

Varec provides two options for tank bottom, guide wire anchors, in-service and out-of-service anchors. An anchor that can be welded to the tank bottom is used when the tank is out-of-service (Part #AA1025). A weight can be used as an alternative when the installation is performed while the tank is in service (Part #BA4481).

Varec top guide wire anchors can be screwed or welded into the tank roof, maintenance hatch, or manhole cover.

Support Brackets

“A” frame brackets support the conduit (pipework) that carries the tape. These brackets can be welded or bolted to the tank and should be placed at regular intervals (approx. 10ft or 3 meters) to provide uniform support. The pipework should be held rigidly in place and correctly aligned so that the tape does not touch or rub the internal pipework.

The steel pipe support bracket is used on the side of the tank (Part #B5643-003). The upper support bracket assembly is used at the tank top (Part #BM717).

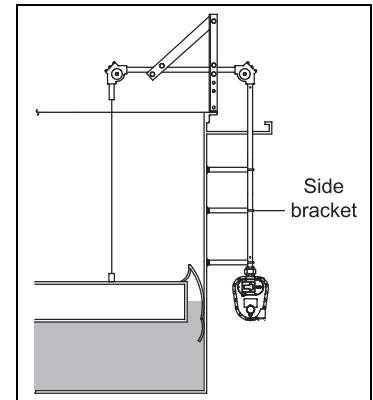

Figure 2-1: Support brackets and conduit shown on an external floating roof tank

Conduit (Pipework) and Couplings

Plan the pipe routing and make sure you have the required conduit, elbows, and other materials needed. Couplings and unions can be used to easily connect sections of pipework together without welding. They also provide a means to maintain the pipework, tape and gauge head. Vertical runs must be plumbed to be perpendicular to prevent the tape from binding inside the pipe.

The pipe carrying the perforated tape must be attached to the tank by welding the supplied brackets. If the environment is such that welding cannot be performed, the user can construct a support structure with 3-inch (DN80) pipe or conduit close to the outside of the tank. The brackets can be welded to the support structure at another location, if necessary, and the pipe structure assembled at the tank site.

Conduit Elbows

Conduit elbows reduce friction and wear on the tape and provide various installation options, depending on the tank type. Varec can provide various angles, materials, and low/high pressure options.

Conduit Oil Seals (Optional)

Oil seals designed into the conduit pipework during installation can help reduce wear and maintenance on the tape, conduit, and gauge head parts. These optional seals also prevent the loss of damaging fumes or corrosive vapors.

Oil seals are rated for 8.5" (215 mm) wc and 27" (685 mm) wc respectively. Sealing fluid must have a minimum specific gravity of 0.84 for the oil seal to maintain integrity. Contact Varec Technical Support for assistance if the sealing fluid does not meet this criteria.

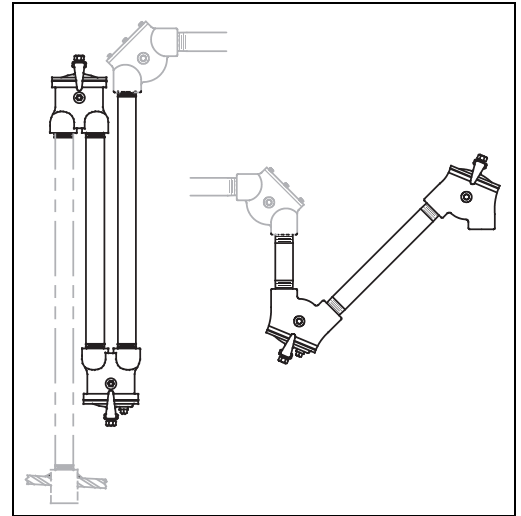
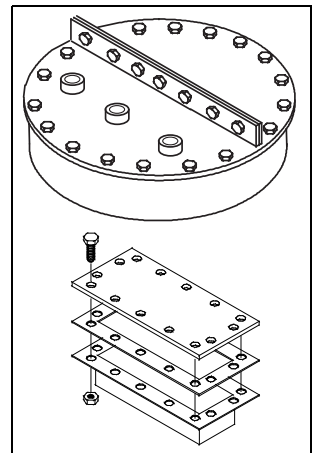

Figure 2-2: Conduit Oil Seals

Tank Roof Entry via Manhole & Inspection Covers

Varec highly recommends a manhole or inspection cover be installed for ease of installation and maintenance of the float, tape, and guide wires. Tape conduit and guide wire anchor entries into the tank roof should be near an existing manhole cover (within arms reach) or be made through a manhole cover. If this is not the case, install a manhole or inspection hatch.

A manhole cover (Model 226) allows for in-service installation of the 2500 ATG through a tank's existing manway. Each of the three port entries is threaded for simple installation of pipework or guide wire anchors. (Part #BM3443 for 20" API, Part #BM3607 for 24" API).



An inspection cover (Model 228) can be installed onto an existing manhole cover, or directly on the tank roof, next to the three port entries to provide an easily removable inspection plate (Part # BM6746).

Figure 2-3: Inspection and Manhole Covers

Floats

For new installations, locate the float in the tank where it will be exposed to a minimum of agitation. If the product stream is close to the float, install a deflector. If agitators will cause excess float disturbances, contact Varec before proceeding with installation.

The 2500 ATG is provided with a standard 14.5" (368 mm) float diameter (with 17" (432 mm) guides) Type 316 stainless steel hollow shell float. Depending on the type of service kit selected — moderate, severe, or extreme — an alternative float may be supplied.



Figure 2-4: Standard 2500 ATG Flat Hollow Shell Float and 6" Interface Float

Identifying Your Installation Type

Various accessories are provided, depending on the installation type selected, in the product order codes.

Cone Roof Tank

Order Code T01, T11, T21, T22, T23, T24, T31, T33, T34 T41, T42

Installation parts supplied include:

- 90° Elbow assembly (x2)
- Gauge 'U' bolt kit
- Guide Wire bottom anchor
- Guide Wires
- Support bracket (x6)
- Gauge head and tape
- Float
- Guide Wire top anchors (x2)
- Tape connectors

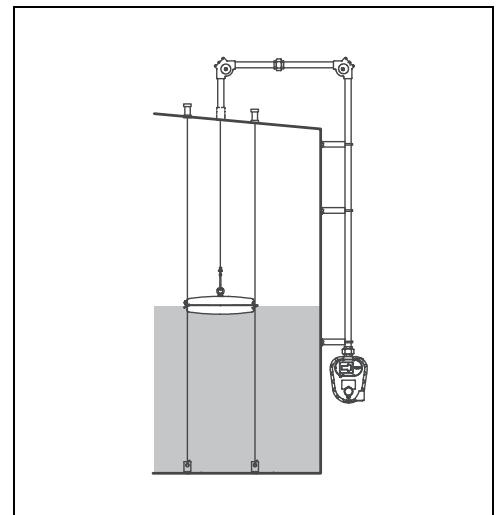

Figure 2-5: Cone Roof Tank

Installation Steps Checklist

When installing a 2500 ATG system on a cone roof tank, complete each installation step below. Check off a step when it is complete. Refer to Chapter 3, "Installation Schematics" on page 35 for overall dimensions.

| Step | "Description" and Page Number | Complete |
|------|--|----------|
| 1 | "Tank Roof Entry – Cone Roof Tank" on page 38 | |
| 2 | "Installing Anchors and Guide Wires" on page 41 | |
| 3 | "Installing Support Brackets & Pipework" on page 42 | |
| 4 | "Installing a Gauge Head at Grade Level" on page 43 | |
| 5 | "Float installation on an Out-of-Service Tank" on page 44 | |
| 6 | "Connecting the Tape to the Float" on page 45 | |
| 7 | "Feeding the Tape to a Gauge Head Located at Grade Level" on page 49 | |
| 8 | "Install Tape in the Gauge Head" on page 50 | |
| 9 | "Reset the Counter" on page 55 | |
| 10 | "Calibrate the Counter" on page 60 | |
| 11 | "Initial Lubrication" on page 61 | |
| 12 | "Install a Transmitter and Replace all Covers" on page 62 | |
| 13 | "Initial Operation" on page 63 | |

Table 2-2: Cone Roof Tank — Installation Steps Checklist

Bolted Tank

Order Code T05, T15

Installation parts supplied include:

- 90° Elbow assembly (x2)
- Guide Wire bottom anchor
- Guide Wires
- Support bracket assembly
- Support bracket (x7)
- Gauge head and tape
- Float
- Guide Wire top anchors (x2)
- Tape connectors
- 1-1/2 Deck flange

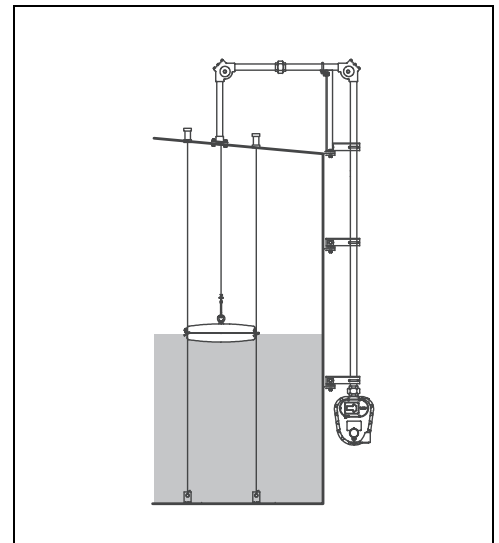

Figure 2-6: Bolted Tank

Installation Checklist

When installing a 2500 ATG system on a bolted tank, complete each installation step below. Check off a step when it is complete. Refer to Chapter 3, "Installation Schematics" on page 35 for overall dimensions.

| Step | Description | Complete |
|------|--|----------|
| 1 | "Tank Roof Entry – Internal Pan (Floating Roof)" on page 39 | |
| 2 | "Installing Anchors and Guide Wires" on page 41 | |
| 3 | "Installing Support Brackets & Pipework" on page 42 | |
| 4 | "Installing a Gauge Head at Grade Level" on page 43 | |
| 5 | "Float installation on an Out-of-Service Tank" on page 44 | |
| 6 | "Connecting the Tape to the Float" on page 45 | |
| 7 | "Feeding the Tape to a Gauge Head Located at Grade Level" on page 49 | |
| 8 | "Install Tape in the Gauge Head" on page 50 | |
| 9 | "Reset the Counter" on page 55 | |
| 10 | "Calibrate the Counter" on page 60 | |
| 11 | "Initial Lubrication" on page 61 | |
| 12 | "Install a Transmitter and Replace all Covers" on page 62 | |
| 13 | " | |

Table 2-3: Bolted Tank — Installation Checklist

Cone Roof Tank with Internal (Floating Roof) Pan and Floatwell

Order Code T02, T12

Installation parts supplied include:

- 90° Elbow assembly (x2)
- Gauge 'U' bolt kit
- Support bracket (x6)
- Gauge head and tape/cable
- Float
- Tape cable connectors

Figure 2-7: Cone Roof Tank with (Internal Floating) Roof Pan and Floatwell

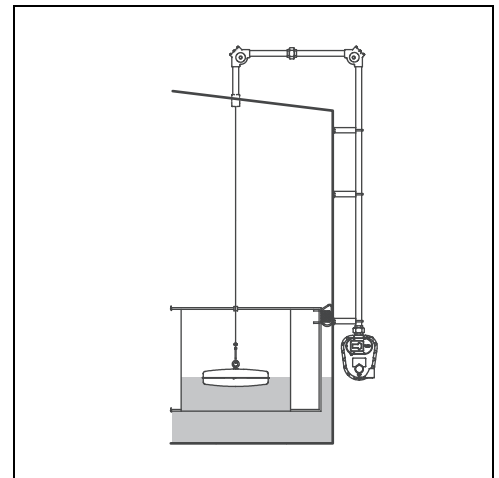

Installation Checklist

When installing a 2500 ATG system on a Cone Roof Tank with Internal (Floating Roof) Pan and Floatwell, complete each installation step below. Check off a step when it is

complete. Refer to Chapter 3, "Installation Schematics" on page 35 for overall dimensions.

| Step | Description | Complete |
|------|---|----------|
| 1 | "Tank Roof Entry – Internal Pan (Floating Roof)" on page 39 | |
| 2 | "Installing Support Brackets & Pipework" on page 42 | |
| 3 | "Installing a Gauge Head at Grade Level" on page 43 | |
| 4 | "Float installation on an Out-of-Service Tank" on page 44 | |
| 5 | "Connecting the Tape to a 6" Interface Float in an 8" Stilling Well" on page 48 | |
| 6 | "Feeding the Tape to a Gauge Head Located at Grade Level" on page 49 | |
| 7 | "Install Tape in the Gauge Head" on page 50 | |
| 8 | "Trimming the Cable at the Float in a Floatwell" on page 55 | |
| 9 | "Reset the Counter" on page 55 | |
| 10 | "Calibrate the Counter" on page 60 | |
| 11 | "Initial Lubrication" on page 61 | |
| 12 | "Install a Transmitter and Replace all Covers" on page 62 | |
| 13 | " on page 63 | |

Table 2-4: Cone Roof Tank with Internal (Floating Roof) Pan and Floatwell — Installation Checklist

Cone Roof Tank and Internal (Floating Roof) Pan: No Floatwell

Order Code T07, T17

Installation parts supplied include:

- 90° Elbow assembly (x2)
- Gauge 'U' bolt kit
- Support bracket (x6)
- Gauge head and tape/cable
- Tape cable connectors

Figure 2-8: Cone Roof Tank and Internal (Floating Roof) Pan: No Floatwell Installation

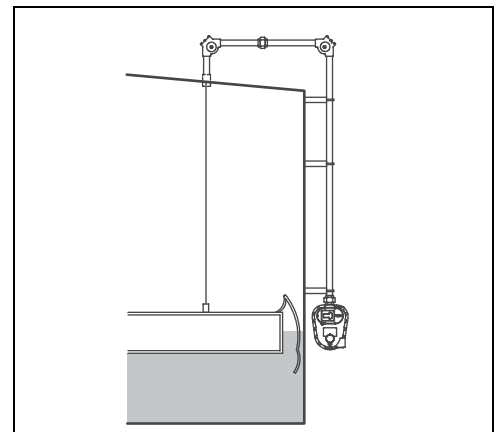

Installation Checklist

When installing a 2500 ATG system on a Cone Roof Tank and Internal (Floating Roof) Pan without a Floatwell, complete each installation step below. Check off a step when it is complete. Refer to Chapter 3, "Installation Schematics" on page 35 for overall dimensions.

Note Due to the resulting gross measurement inaccuracies, Varec does not recommend that the perforated tape/tape cable be attached directly to a floating pan. Use a covered floatwell for the best measurement accuracy.

| Step | Description | Complete |
|------|--|----------|
| 1 | "Tank Roof Entry – Internal Pan (Floating Roof)" on page 39 | |
| 2 | "Installing Support Brackets & Pipework" on page 42 | |
| 3 | "Installing a Gauge Head at Grade Level" on page 43 | |
| 4 | "Connecting the Cable to a Floating Pan" on page 47 | |
| 5 | "Feeding the Tape to a Gauge Head Located at Grade Level" on page 49 | |
| 6 | "Install Tape in the Gauge Head" on page 50 | |
| 7 | "Reset the Counter" on page 55 | |
| 8 | "Calibrate the Counter" on page 60 | |
| 9 | "Initial Lubrication" on page 61 | |
| 10 | "Install a Transmitter and Replace all Covers" on page 62 | |
| 11 | "Initial Operation" on page 63 | |

Table 2-5: Cone Roof Tank and Internal (Floating Roof) Pan: No Floatwell — Installation Checklist

Tank Top Mounting

Order Code T04, T14, T24, T32

Installation parts supplied include:

- Gauge 'U' bolt kit
- Guide Wire bottom anchor
- Guide Wires
- Gauge head and tape
- Float
- Guide Wire top anchors (x2)
- Tape connectors

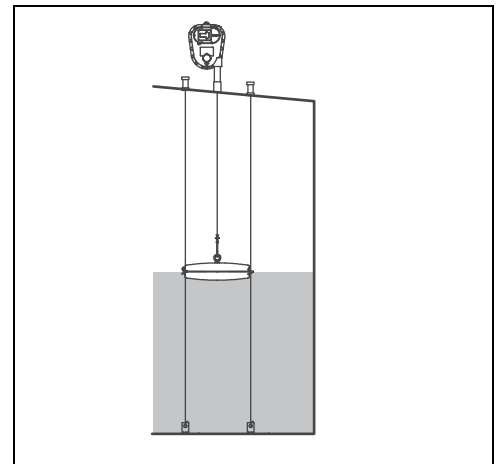

Figure 2-9: Tank Top Mounting

Installation Checklist

When installing a 2500 ATG system on a cone roof tank, complete each installation step below. Check off a step when it is complete. Refer to Chapter 3, "Installation Schematics" on page 35 for overall dimensions.

| Step | Description | Complete |
|------|---|----------|
| 1 | Section "Tank Roof Entry – Cone Roof Tank" on page 38 | |
| 2 | Section "Installing Anchors and Guide Wires" on page 41 | |
| 3 | Section "Installing a Roof Reading Gauge Head" on page 44 | |
| 4 | Section "Float installation on an Out-of-Service Tank" on page 44 | |
| 5 | Section "Connecting the Tape to the Float" on page 45 | |
| 6 | Section "Install Tape in the Gauge Head" on page 50 | |
| 7 | Section "Reset the Counter" on page 55 | |
| 8 | Section "Calibrate the Counter" on page 60 | |
| 9 | Section "Initial Lubrication" on page 61 | |
| 10 | Section "Install a Transmitter and Replace all Covers" on page 62 | |
| 11 | Section "Initial Operation" on page 63 | |

Table 2-6: Tank Top Mounting — Installation Checklist

Stilling Well Service Cone Roof Tank 6" Diameter Float

Order Code T55, T56

Installation parts supplied include:

- 90° Elbow assembly (x2)
- Gauge 'U' bolt kit
- Support bracket (x6)
- Gauge head and tape
- Float
- Tape connectors

Figure 2-10: Stilling Well Service Cone Roof Tank 6" Diameter Float

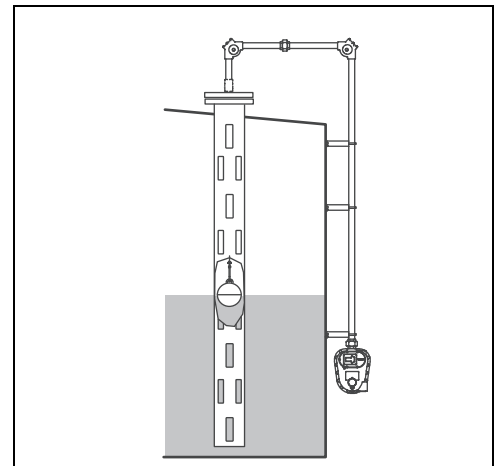

Installation Checklist

When installing a 2500 ATG system on a Stilling Well Service Cone Roof Tank 6" Diameter Float, complete each installation step below. Check off a step when it is complete. Refer to Chapter 3, "Installation Schematics" on page 35 for overall dimensions.

| Step | Description | Complete |
|------|---|----------|
| 1 | Section "Tank Roof Entry - Stilling Well" on page 40 | |
| 2 | Section "Installing Support Brackets & Pipework" on page 42 | |
| 3 | Section "Installing a Gauge Head at Grade Level" on page 43 | |
| 4 | Section "Float installation on an Out-of-Service Tank" on page 44 | |
| 5 | Section "Connecting the Tape to a 6" Interface Float in an 8" Stilling Well" on page 48 | |
| 6 | Section "Feeding the Tape to a Gauge Head Located at Grade Level" on page 49 | |
| 7 | Section "Install Tape in the Gauge Head" on page 50 | |
| 8 | Section "Reset the Counter" on page 55 | |
| 9 | Section "Calibrate the Counter" on page 60 | |
| 10 | Section "Initial Lubrication" on page 61 | |
| 11 | Section "Install a Transmitter and Replace all Covers" on page 62 | |
| 12 | Section "Initial Operation" on page 63 | |

Table 2-7: Stilling Well Service Cone Roof Tank 6" Diameter Float — Installation Checklist

External Floating Roof Tank and Floatwell

Order Code T03, T13

Installation parts supplied include:

- 90° Elbow assembly (x2)
- Gauge 'U' bolt kit
- Support bracket assembly
- Support bracket (x6)
- Gauge head and tape /cable
- Float
- Tape/cable connectors

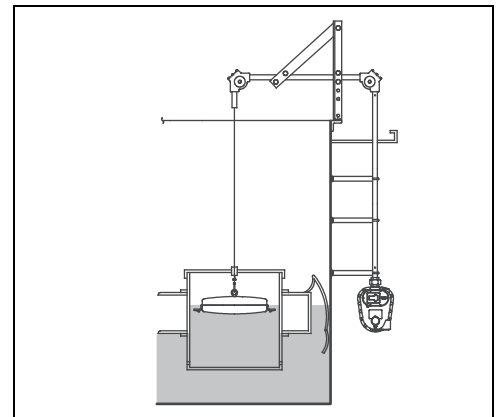

Figure 2-11: External Floating Roof Tank and Floatwell

Installation Checklist

When installing a 2500 ATG system on a External Floating Roof Tank and Floatwell, complete each installation step below. Check off a step when it is complete. Refer to Chapter 3, "Installation Schematics" on page 35 for overall dimensions.

| Step | Description | Complete |
|------|--|----------|
| 1 | Section "Correct Float Positioning for an External Floating Pan Installation" on page 40 | |
| 2 | Section "Installing Support Brackets & Pipework" on page 42 | |
| 3 | Section "Installing a Gauge Head at Grade Level" on page 43 | |
| 4 | Section "Float installation on an Out-of-Service Tank" on page 44 | |
| 5 | Section "Connecting the Cable to a Float in a Floatwell" on page 46 | |
| 6 | Section "Feeding the Tape to a Gauge Head Located at Grade Level" on page 49 | |
| 7 | Section "Install Tape in the Gauge Head" on page 50 | |
| 8 | Section "Trimming the Cable at the Float in a Floatwell" on page 55 | |
| 9 | Section "Reset the Counter" on page 55 | |
| 10 | Section "Calibrate the Counter" on page 60 | |
| 11 | Section "Initial Lubrication" on page 61 | |
| 12 | Section "Install a Transmitter and Replace all Covers" on page 62 | |
| 13 | Section "Initial Operation" on page 63 | |

Table 2-8: External Floating Roof Tank and Floatwell — Installation Checklist

External Floating Roof Tank: No Floatwell

Order Code T06, T16

Installation parts supplied include:

- 90° Elbow assembly (x2)
- Gauge 'U' bolt kit
- Support bracket assembly
- Support bracket (x6)
- Gauge head and tape/cable
- Tape/cable connectors

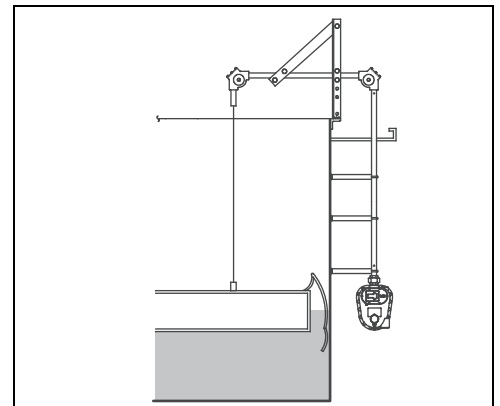

Figure 2-12: External Floating Roof Tank: No Floatwell

Installation Checklist

When installing a 2500 ATG system on a cone roof tank, complete each installation step below. Check off a step when it is complete. Refer to Chapter 3, "Installation Schematics" on page 35 for overall dimensions.

Note Due to the resulting gross measurement inaccuracies, Varec does not recommend that the perforated tape/tape cable be attached directly to a floating pan. Use a covered floatwell for the best measurement accuracy.

| Step | Description | Complete |
|------|--|----------|
| 1 | Section "Correct Float Positioning for an External Floating Pan Installation" on page 40 | |
| 2 | Section "Installing Support Brackets & Pipework" on page 42 | |
| 3 | Section "Installing a Gauge Head at Grade Level" on page 43 | |
| 4 | Section "Connecting the Cable to a Floating Pan" on page 47 | |
| 5 | Section "Feeding the Tape to a Gauge Head Located at Grade Level" on page 49 | |
| 6 | Section "Install Tape in the Gauge Head" on page 50 | |
| 7 | Section "Reset the Counter" on page 55 | |
| 8 | Section "Calibrate the Counter" on page 60 | |
| 9 | Section "Initial Lubrication" on page 61 | |
| 10 | Section "Install a Transmitter and Replace all Covers" on page 62 | |
| 11 | Section "Initial Operation" on page 63 | |

Table 2-9: External Floating Roof Tank: No Floatwell — Installation Checklist

Interface Service

Order Code T51, T52, T53, T54

Installation parts supplied include:

- 90° Elbow assembly (x2)
- Gauge 'U' bolt kit
- Guide Wire bottom anchor
- Guide Wires
- Support bracket (x6)
- Gauge head and tape
- Interface float
- Guide Wire top anchors (x2)
- Tape connectors

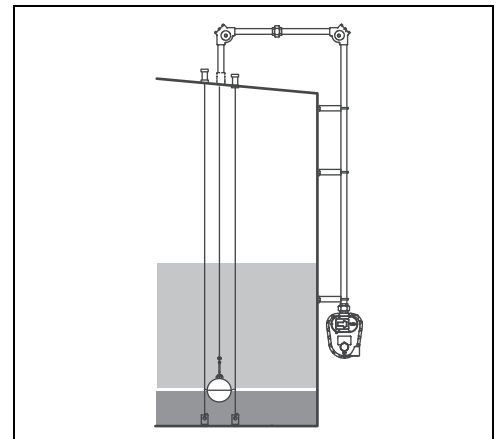

Figure 2-13: Interface Service

Installation Checklist

When installing a 2500 ATG system on a cone roof tank, complete each installation step below. Check off a step when it is complete. Refer to Chapter 3, "Installation Schematics" on page 35 for overall dimensions.

| Step | Description | Complete |
|------|--|----------|
| 1 | Section "Tank Roof Entry – Cone Roof Tank" on page 38 | |
| 2 | Section "Installing Anchors and Guide Wires" on page 41 | |
| 3 | Section "Installing Support Brackets & Pipework" on page 42 | |
| 4 | Section "Installing a Gauge Head at Grade Level" on page 43 | |
| 5 | Section "Float installation on an Out-of-Service Tank" on page 44 | |
| 6 | Section "Connecting the Tape to the Float" on page 45 | |
| 7 | Section "Feeding the Tape to a Gauge Head Located at Grade Level" on page 49 | |
| 8 | Section "Install Tape in the Gauge Head" on page 50 | |
| 9 | Section "Reset the Counter" on page 55 | |
| 10 | Section "Calibrate the Counter" on page 60 | |
| 11 | Section "Initial Lubrication" on page 61 | |
| 12 | Section "Install a Transmitter and Replace all Covers" on page 62 | |
| 13 | Section "Initial Operation" on page 63 | |

Table 2-10: Interface Service — Installation Checklist

3 Installation

This chapter gives instructions for the various types of installations based on the order code options for the 2500 ATG.

Note Before installing your 2500 ATG, read and review all see the “Safety Precautions” section of the preface to this document. Continuing with installation according to the instructions in this manual presumes you have reviewed these safety precautions.

Note Refer to Chapter 2, Identifying Your Installation Type before proceeding.

Installation Schematics

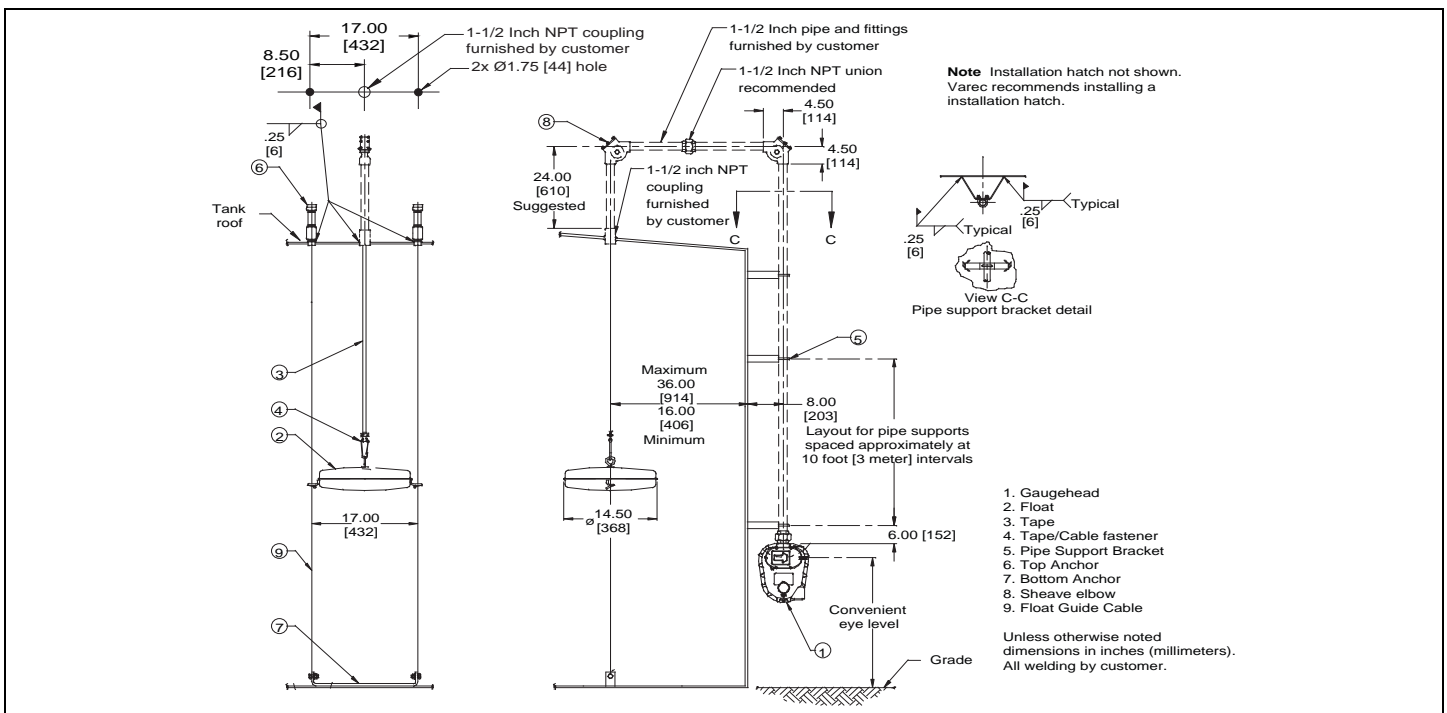

Figure 3-1: Cone Roof Tank

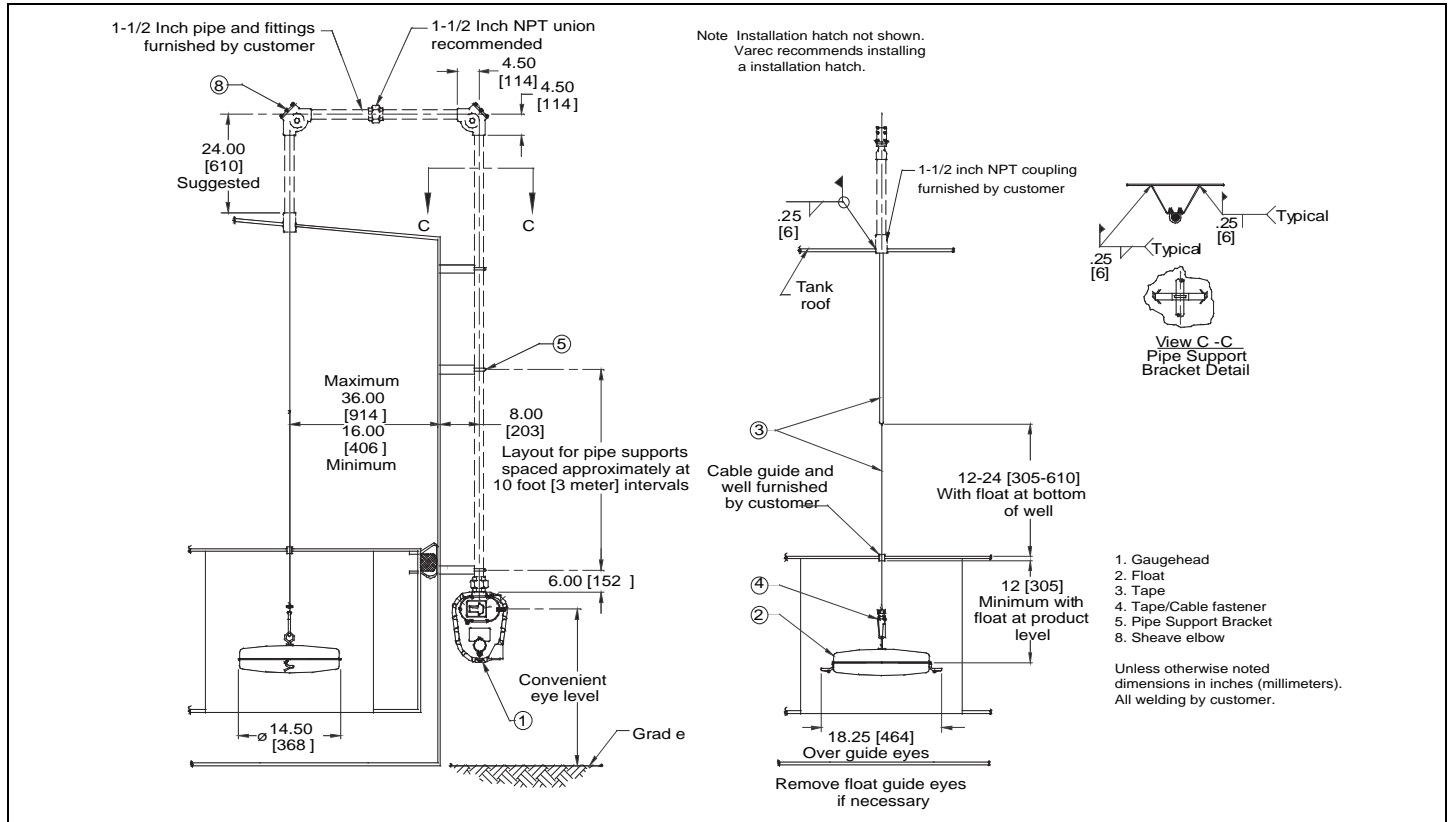

Figure 3-2: Cone Roof Tank with Internal Pan (Floating Roof)

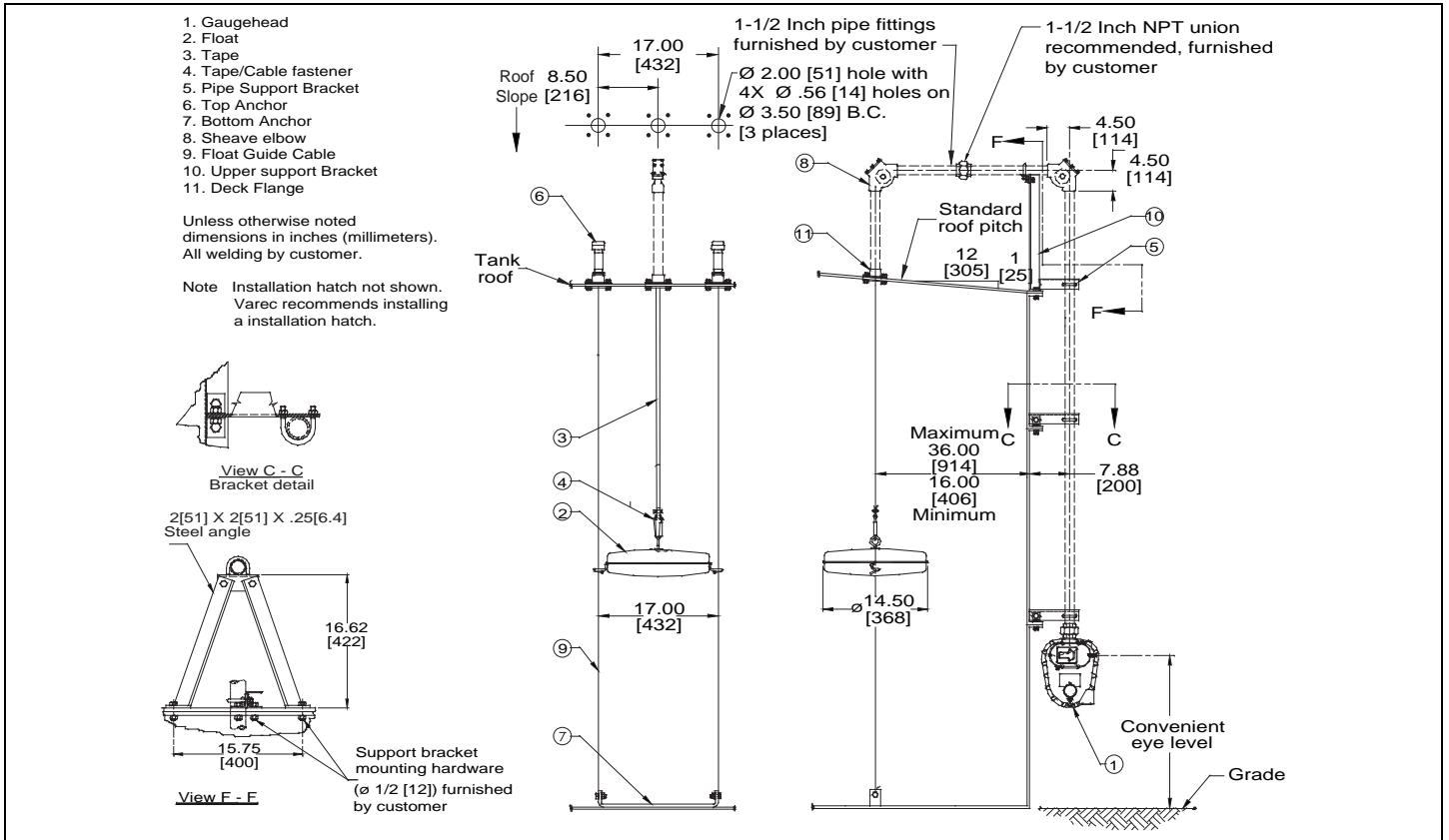

Figure 3-3: Bolted Cone Roof Tank

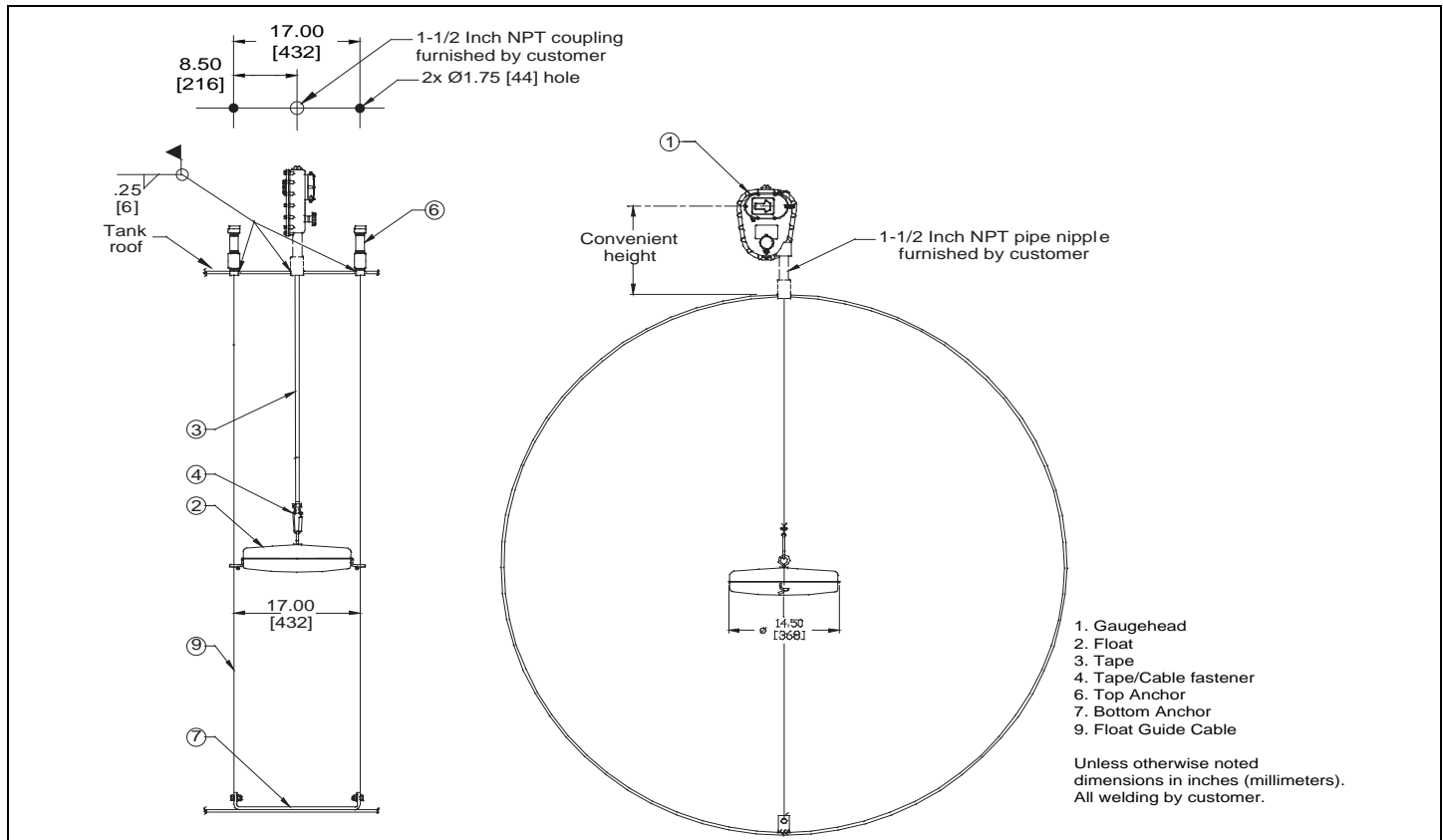

Figure 3-4: Horizontal Bullet Tank with Roof Reading Gauge

Tank Roof Entry - Cone Roof Tank

Note Ensure you have completed all previous steps from your installation checklist before proceeding.

Note Varec recommends the installation of a manhole cover as shown in Figure 4-1 on page 68

1. Determine the position on the tank roof beneath which the center of the float will rise and fall (Measuring Point). Notice that this position is located a minimum of 16 inches (406 mm) and a maximum of 36.00 inches (914 mm) from the wall of the tank.
2. Provide the roof holes centered on this position. For installations without guide wires only the center hole for the tape pipe is required.
 - The float diameter is 14.50 inches (368 mm). The guide cable holes are centered 8.50 inches (216 mm), each side of the center of the float.
3. If performing a Bolted Cone Roof type installation, check the angle of the roof. The supplied mounting bracket for the gauge head is designed for a 1/12 roof pitch (1 inch [25 mm] rise over 12 in [300 mm] run).

4. Screw the “drop” pipe coupling into the vertical pipe nipple. This will aid in positioning the coupling, while welding.
5. Check the pitch of the roof. Hold the coupling plumb, while welding it into the hole in the roof.

Note Failure to place the coupling and pipe in a true vertical position may affect the accuracy of the gauge.

6. After the coupling and pipe are checked to make certain that they are plumb, unscrew the pipe from the coupling.

Note Make sure that the interior of all pipes are clean and corrosion free.

7. Seal the threads with pipe thread compound and reconnect the pipe to the coupling.

Tank Roof Entry - Internal Pan (Floating Roof)

1. To facilitate inspection and service of the gauge system, locate the well where gauge piping will pass over the top of the tank shell close to a stairway platform.
Note Due to the resulting gross measurement inaccuracies, Varec does not recommend that the perforated tape/tape cable be attached directly to a floating pan. Use a covered floatwell for the best measurement accuracy.
2. Determine the center point of the float well. Varec recommends this position is located a minimum of 16.00 inches (406 mm) and a maximum of 36.00 inches (916 mm) from the wall of the tank.
3. Provide the roof hole for the conduit pipework centered on this position. For installations without guide wires, only the center hole is required.
4. Drill a small hole in the roof. Check that a line dropped through this hole is plumb to the center point of the well. If it lines up with the center point of the well enlarge the hole to accommodate the coupling for the 1.5 inch (DN40) pipe.
5. Screw the “drop” pipe coupling into the vertical pipe nipple. This will aid in positioning the coupling while welding.
6. Check the pitch of the roof. Hold the coupling plumb while welding it into the hole in the roof.

Note Failure to place the coupling and pipe in a true vertical position may affect the accuracy of the gauge.

7. After the coupling and pipe are checked to make certain that they are plumb, unscrew the pipe from the coupling.

Note Make sure that the interior of all pipes are clean and corrosion free.

8. Seal the threads with a pipe thread compound and reconnect the pipe to the coupling.

Tank Roof Entry - Stilling Well

Note To facilitate inspection and service of the gauge system, locate the well where gauge piping will pass over the top of the tank shell close to a stairway platform.

1. In a user-supplied flange that is suitable to connect to the stilling well on your tank, provide a center hole for the conduit to screw into the flange.
2. Connect the conduit to the flange.

Note Failure to place the coupling and pipe in a true vertical position may affect the accuracy of the gauge.

3. After the coupling and pipe are checked to make certain that they are plumb, unscrew the pipe from the flange.

Note Make sure that the interior of all pipes are clean and corrosion free.

4. Seal the threads with a pipe thread compound and reconnect the pipe to the flange.

Correct Float Positioning for an External Floating Pan Installation

Note Ensure you have completed all previous steps from your installation checklist before proceeding.

Note To facilitate inspection and service of the gauge system, locate the well where gauge piping will pass over the top of the tank shell close to a stairway platform.

Note The total float travel distance must be less than the height of the outboard vertical pipe. This allows the tape and tape cable splice to reside in the vertical pipe throughout the total travel of the roof.

1. Determine the position of the center point at which the float will rise and fall (center point of the floatwell or point on the pan where the cable will attach). Varec recommends this position is located a minimum of 16 inches (406 mm) and a maximum of 36 inches (916 mm) from the wall of the tank.

2. Extend a vertical line from this point up to the tank roof/position of the support brackets that will hold the conduit.

Installing Anchors and Guide Wires

Note Ensure you have completed all previous steps from your installation checklist before proceeding.

1. Center the base of a top cable anchor in its hole. Hold it plumb while welding or bolting it to the roof.
2. Do the same for the other top cable anchor.

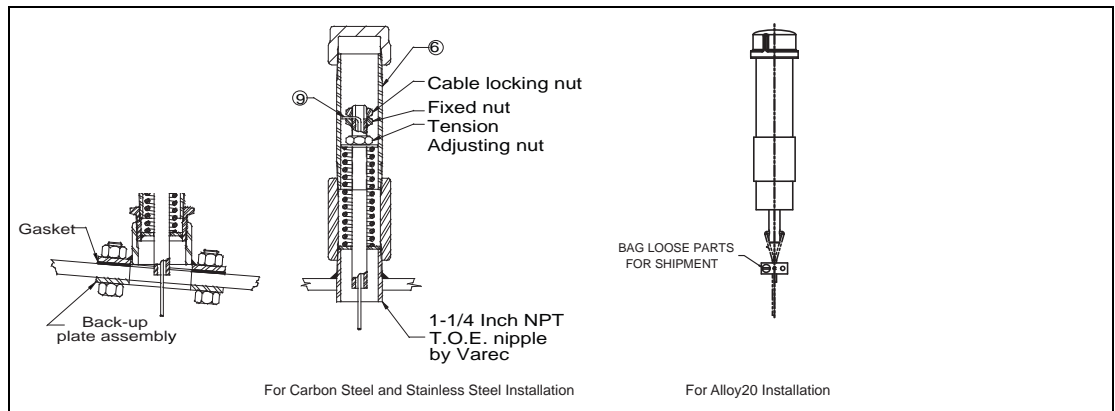

Figure 3-5: Detail A - Top Anchors

3. Remove the housing nipple and cap from the top cable anchors and hang plumb lines from their centers to mark the position where the bottom cable anchor will be welded to the tank floor. Mark these positions on the tank floor.
4. Mark the plumb bob string at the height of the tank bench mark. This will assure that the plumb bob just touches the bottom, when the reference is made from the bench mark distance to the bottom.
5. Hang a plumb line through the center of the top tape pipe to the bottom to mark the float center. This should be 8.50 inches (216 mm) from each of the cable anchor positions previously marked on the tank floor.

For Carbon Steel and Stainless Steel:

6. When the positioning has been checked, weld the bottom cable anchor into place.
7. Thread the float guide cables into the tank through the top anchor fittings. Fasten them to the bottom cable anchor with the furnished hardware.

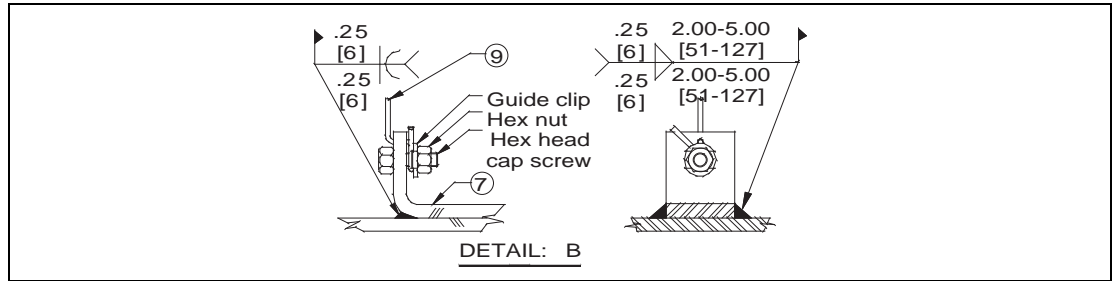

Figure 3-6: Detail D - Bottom Anchor Weight

8. Thread the upper end of each guide cable through the top anchor assembly. Hand tighten.
9. Use the lock nut to lock the cable in place, and then tighten the adjustment nut until the guide cable is tensioned by the spring.
10. Trim off excess cable and replace the housing nipple and cap.

For Alloy20:

11. Loop cable through the top anchor rod.
12. Use the cable clamp to secure.
13. Thread the cable through the anchor, pull the cable tight, and tighten the bottom anchor to secure.
14. Trim excess cable, if needed.

Installing Support Brackets & Pipework

Note Ensure you have completed all previous steps from your installation checklist before proceeding.

Note The pipe carrying the perforated tape must be attached to the tank by welding the supplied brackets. If the environment is such that welding cannot be performed, the user can construct a support structure with 3 inch (DN80) pipe or conduit close to the outside of the tank. The brackets can be welded to the support structure at another location, if necessary, and the pipe structure assembled at the tank site.

1. Weld or bolt the pipe support brackets into place. When installing the conduit (pipework) start installing conduit and sheave elbows from the tank entry point to the gauge head at grade level.
2. Apply pipe thread compound and install the sheave elbow on the vertical pipe to the tank interior, then install the horizontal pipe into that elbow.
3. Install the other elbow on the horizontal pipe.

4. Mount the exterior vertical pipe into the support brackets and screw it into the upper elbow.
5. Tighten the support bracket nuts.
6. Remove the bolts, covers, and gaskets from the elbows.

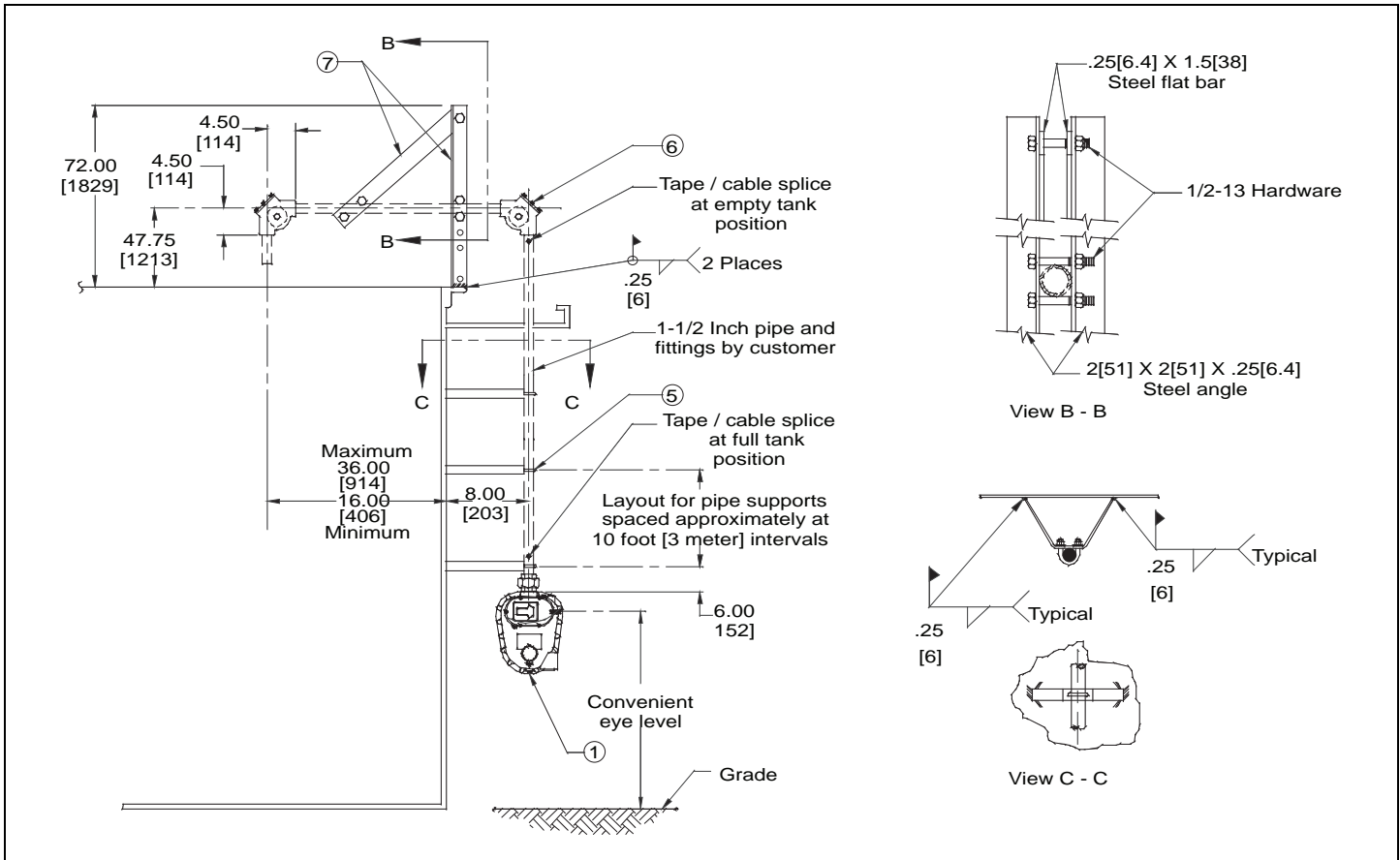

Figure 3-7: Example Support Bracket Installation

Installing a Gauge Head at Grade Level

Note Ensure you have completed all previous steps from your installation checklist before proceeding.

Warning! When removing the gauge head back cover, stand to one side as the last bolt is removed. If the negator motor spring is broken, the broken pieces may cause injury when the cover is removed.

1. Remove the back cover and gasket from the gauge head.

Note The weight of the installed gauge head is supported by the pipe and brackets.

2. Apply pipe thread compound and attach the gauge head to the exterior vertical pipe.
Position it for convenient reading.

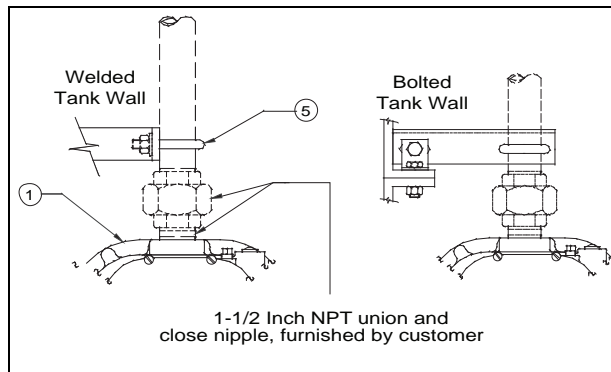

Figure 3-8: Conduit Connection and Tank Side Support Bracket Details

Installing a Roof Reading Gauge Head

Note Ensure you have completed all previous steps from your installation checklist before proceeding.

Warning! When removing the gauge head back cover, stand to one side as the last bolt is removed. If the negator motor spring is broken, the broken pieces may cause injury when the cover is removed.

1. Remove the back cover and gasket from the gauge head.
2. Apply pipe thread compound and attach the gauge head to the exterior vertical pipe.
Position it for convenient reading.

Float installation on an Out-of-Service Tank

Note Be sure to read Chapter 2, General Preparation before proceeding with this installation. Ensure you have completed all previous steps from your installation checklist before proceeding.

Cone Roof Tank

From inside the tank, tilt the float on edge and slip the guide cables through the loops. Set the float on the tank bottom with the tape connection up.

Floating Pan with Floatwell

Note The float's guide wires should be removed (cut off) as it is possible for these to get caught on the sides of the floatwell.

Rest the float at the bottom of the tank in the float well (lowest measuring point).

Connecting the Tape to the Float

Note Be sure to read Chapter 2, General Preparation before proceeding with this installation. Ensure you have completed all previous steps from your installation checklist before proceeding.

1. Using the box that the tape came in, pull the tape out like a measuring tape. This keeps the tape from becoming twisted or kinked.

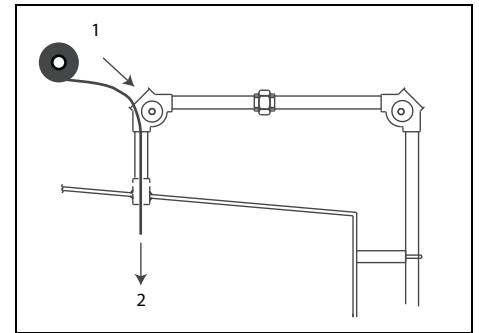

Figure 3-9: Feed the Tape into the Tank

2. At the elbow on the tank entry pipe, unroll one or two turns of the perforated tape and start to feed it into the tank. If your installation is a roof-reading application with the gauge head installed on the conduit on the roof, feed the tape through the back of the gauge head first. Continue to unroll it several turns at a time until it reaches the bottom of the tank. Let several more inches fall on the tank bottom.
3. Cut a 6-inch (152 mm) piece of tape from the end inside of the tank. Form a 'U' with this piece of tape so there is no hole in the bottom portion of the 'U'. Do not kink.

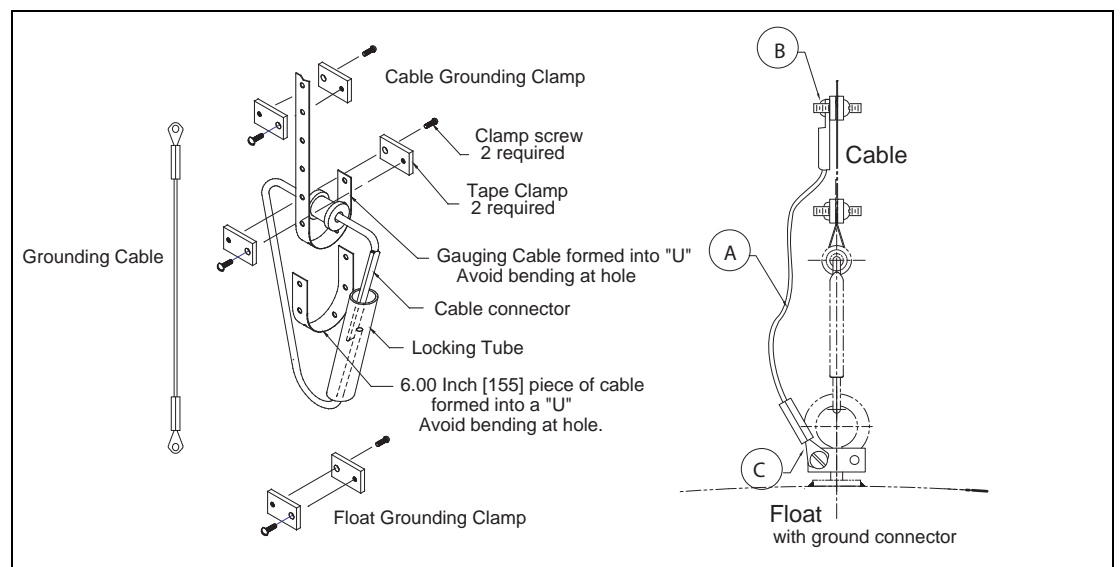

Figure 3-10: Tape Clamp Assembly with Grounding Cable

4. Form a 'U' at the end of the perforated tape. Form it to match the 'U' piece previously formed. Do not kink.
5. Install the gauge tape and 'U' piece to the tape connector with the tape clamps and screws provided, making certain that the tape is not kinked or twisted.
6. Connect the grounding cable (A) to the tape connector (point B).
7. Attach the tape connector to the float.
8. Connect the grounding cable (A) to the float (point C).

Connecting the Cable to a Float in a Floatwell

Note Ensure you have completed all previous steps from your installation checklist before proceeding.

Note On (internal or external) floating pan installations one end of the tape is connected to a cable.

1. At the outboard elbow, feed the cable through the horizontal pipe, over the tank entry elbow and down through the pipe to the floating roof. Check that it is centered on the well. Continue feeding the cable until the tape/tape cable splice is reached.
2. Drop the tape end down through the outboard elbow, vertical pipe and gauge head to the ground cloth. Feed out all tape until the tape/tape cable splice is reached. Position the splice at the bottom end of the vertical outboard elbow connection.
3. If the well is covered, drill a hole in the floating roof to accommodate the cable and a suitable user-furnished guide wire.
4. Enlarge the hole, if one was made in the step above, to accommodate a suitable, user furnished guide wire. Install the guide wire. Make certain that it is plumb.

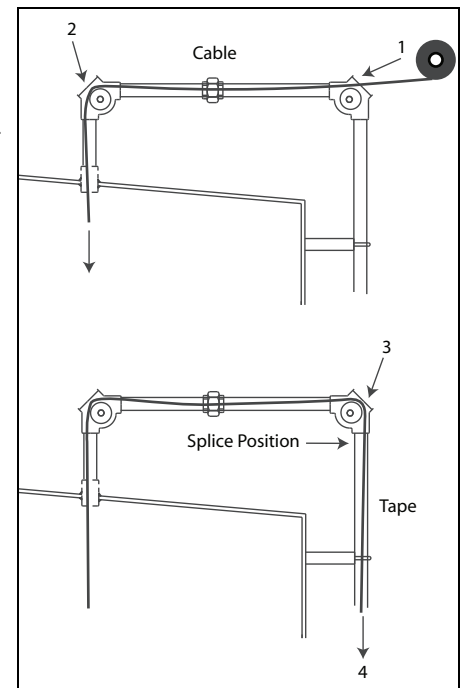

Figure 3-11: Feed the Cable and Tape

5. Thread the cable through the guide wire.
6. Attach the cable to the float with the furnished fastener and ground cable (Figure 3-10).

Note There should be at least 12" (305 mm) clearance between the top of the float at the liquid level and the top of the float well.

7. Put the bottom of the float on the bottom of the tank in the float well.
8. Make certain that the tape/tape cable is not kinked or twisted.

Figure 3-12: Cable Length Calculation

9. Cut the cable to the correct length to ensure the splice between the tape and cable does not run over an elbow pulley or is drawn into the gauge head. Consider Figure 3-12 and apply it to your particular installation or call Varec Help desk with questions.
 - $A+B+C+D-E$ = Correct Cable Length
 - Splice position "x" is optimum for empty or out of service tanks.
 - Maximum fill and minimum read positions should never be greater than the "F" dimension.

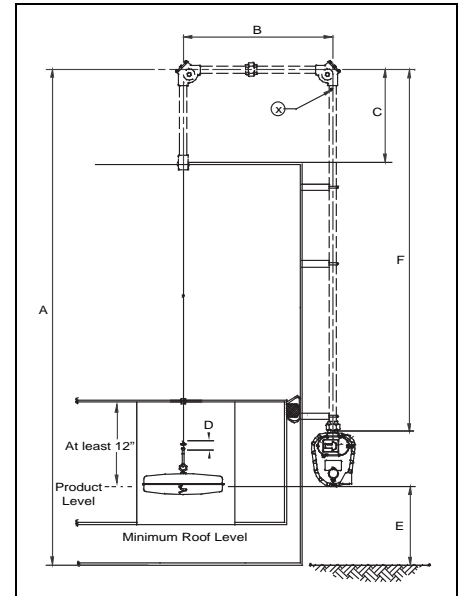

Connecting the Cable to a Floating Pan

Note Ensure you have completed all previous steps from your installation checklist before proceeding.

Note Due to the resulting gross measurement inaccuracies, Varec does not recommend that the perforated tape/tape cable be attached directly to a floating pan. Use a covered floatwell for the best measurement accuracy.

Caution! Connecting a tape/cable directly to a floating pan increases the probability that damage will occur to the tape/cable. Tearing or snapping of the tape/cable could result in damage to the gauge head.

1. If there is no floatwell in the floating roof and no other alternative is available, Varec recommends attaching the tape/cable to an object that is resting (unconnected) on the floating roof.
2. Refer to the previous section for instructions to cut the cable to the correct length.

Connecting the Tape to a 6" Interface Float in an 8" Stilling Well

Note Ensure you have completed all previous steps from your installation checklist before proceeding.

Note The float guide eyes should be removed (cut off) whenever it is possible for the eyelets to get caught on the sides of the stilling well.

1. Using the box that the tape came in, pull the tape out like a measuring tape. This keeps the tape from becoming twisted or kinked.
2. Remove the flange with the conduit entry and elbow from the top of the stilling well. and lay it on the tank roof.
3. At the elbow, unroll one or two turns of the perforated tape and start to feed it into the conduit so that it appears at the bottom of the flange. If your installation is a roof-reading application with the gauge head installed on the conduit, feed the tape through the back of the gauge head first.
4. Cut a 6-inch (152 mm) piece of tape from the end that will be inside of the tank. Form a 'U' with this piece of tape so there is no hole in the bottom portion of the 'U'. Do not kink.
5. Form a 'U' at the end of the perforated tape. Form it to match the 'U' piece previously formed. Do not kink.
6. Install the gauge tape and 'U' piece to the tape connector with the tape clamps and screws provided (Figure 3-10 on page 45).
7. Make certain that the tape is not kinked or twisted.
8. Connect the grounding cable (A) to the tape connector (point B).
9. Attach the tape connector to the float.
10. Connect the grounding cable (A) to the float (point C).
11. Lower the float down the stilling well so that it rests at the bottom of the tank/well (lowest measuring point).
12. Make certain that the tape is not kinked or twisted.
13. Replace the flange onto the stilling well and bolt down.

Feeding the Tape to a Gauge Head Located at Grade Level

Note Ensure you have completed all previous steps from your installation checklist before proceeding.

Note At this point the tape/cable should be connected to the float.

Note The following steps explain how to feed the tape through the conduit from the tank entry point or roof position to the gauge head at grade level.

1. Spread a clean ground cloth below the gauge head and remove the lower tape hole pipe plug.
2. Feed the other end of the tape over the tank entry elbow sheave, through the horizontal pipe (3), and over the sheave in the outboard elbow.
3. Lower the tape through the exterior pipe(4) and down through the gauge head and lower tape hole, then onto the ground cloth(5) until the tape is unrolled. Make sure that the tape does not become kinked or dirty.
4. Check the perforated tape length and trim, if necessary.

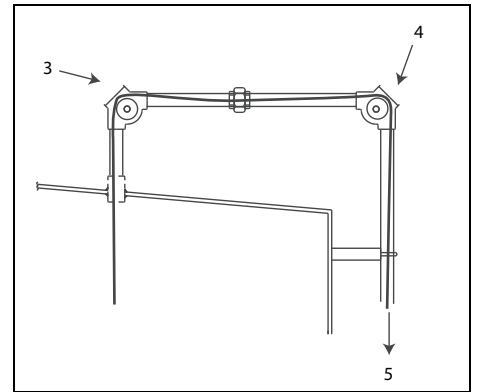

Figure 3-13: Feed the Tape Through the Conduit to the Gauge Head

Note Trimming the tape shorter than 6 feet (1.8 m) could result in the tape end retracting up into the conduit.

5. If the tape extends more than 6 feet (1.8 m) below the gauge head when it is at zero level, trim the excess. Trim the tape about 6 feet (1.8 m) from the bottom of the gauge head.
6. To install the perforated tape in the gauge head, proceed to the section for your type of gauge head:
 - For a Standard 2500 ATG with a Negator Spring Motor, go to “With a Negator Spring Motor” on page 51.
 - For a 2500 ATG with Negator Cassette, go to “With a Negator Cassette” on page 52.
 - For a Hand Crank Type Gauge Head Installation, go to “With a Hand Crank Gauge Head” on page 54.

Install Tape in the Gauge Head

Caution
Do not release crank handle (7) when negator spring motor is being loaded and thumbscrew lock is removed.

- | Item | Description |
|------|------------------------------|
| 1 | Sprocket Sheave |
| 2 | Tape Storage Sheave |
| 3 | ThumbScrew Lock |
| 4 | Tape Keeper |
| 5 | Motor Storage Sheave |
| 6 | Negator Spring Motor |
| 7 | Removable Installation Crank |
| 8 | Negator Spring Motor Screw |
| 9 | Tape Sheave Pinor Screw |

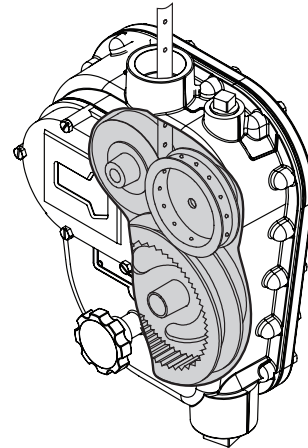

Standard Gaugehead
(Type C with negator spring motor)

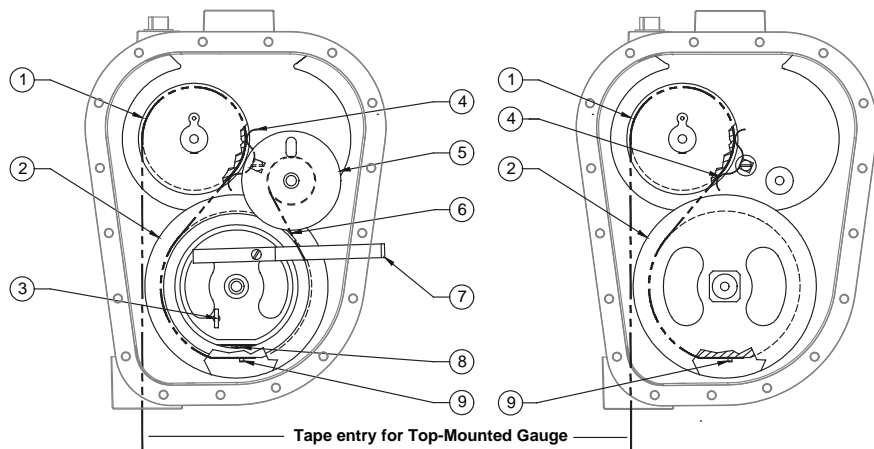

Tape entry for Top-Mounted Gauge

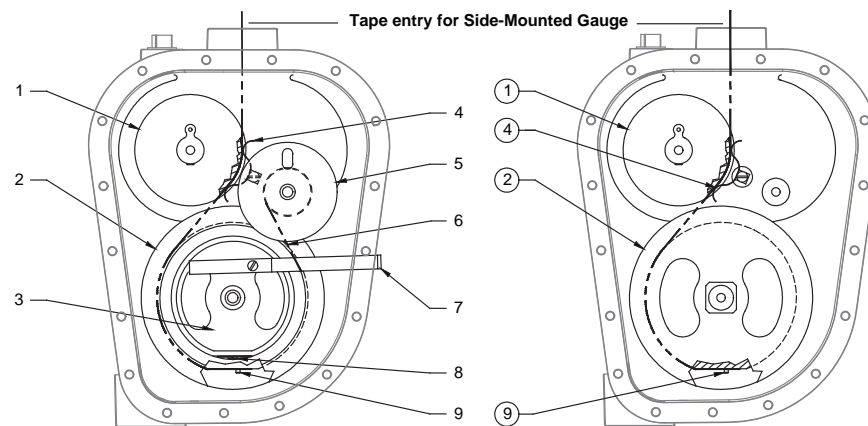

Tape entry for Side-Mounted Gauge

Standard Gaugehead
(with negator spring motor)

Negator Cassette Gaugehead
(shown with negator cassette removed for tape installation)

Figure 3-14: Tape Routing

Warning! Do not over-wind negator motor. Winding motor greater than the indicated number of turns may cause the motor to dislodge and uncoil from its pulley, causing damage to equipment and injury to personnel.

Warning! Use both hands for a firm grasp on the crank while winding motor. Tighten thumbscrew before releasing grip. The rapid unwinding of the spring could result in the crank spinning and striking the operator.

Caution! Do not allow the float to fall back to the floor of the tank. Damage to the float or tank may result.

Note Be sure to remove the installation crank when installation is complete. Do not store the crank or the thumbscrew in the gauge head. Put them in a storage area for safe keeping and future use.

With a Negator Spring Motor

1. If you have a Standard 2500 ATG with a Negator Spring Motor, follow the procedure in this section to install the gauge tape and load the negator motor on the gauge head.
2. Attach the furnished installation crank and thumbscrew to the tape storage sheave.

Wind the storage sheave clockwise, the number of turns indicated in Table 3-1, and then securely tighten the thumbscrew.

| Motor Sheave Part No. | Gauge Head Motor (Normal Application) | Turns w/2500 ATG |
|-----------------------|--|------------------|
| BA7762 | Standard: 0 - 60' (0-18m) tank range | 45 |
| BA17725 | Extra Strong: 0 - 60' (0-18m) tank range | 47 |
| BA17087 | Extra Long: 0 - 90' (0-27m) tank range | 63 |

Table 3-1: Turns to Wind Negator Motor

3. If you have a hand crank type gauge head, ensure that the motor is wound and the ratchet pawl is at mid position (engaged).
4. At the gauge head, put the first hole in the tape on a pin of the sprocket close to the tape guide.
5. Rotate the sprocket clockwise to pull the tape through the guide.
6. Pull the tape around the storage sheave.
7. Fasten the 2nd hole in the tape to the tape storage sheave on the sheave pin.
8. Hold the installation crank firmly and loosen the thumbscrew.
9. While keeping tension on the tape, allow the motor to wind the excess tape counter-clockwise around the storage sheave until all slack is removed.

10. Check the tape path between the float and the gauge head to be sure that it is not kinked or twisted.

Note If you are installing a hand crank type gauge head, proceed now to With a Hand Crank Gauge Head on page 54, step 4.

With a Negator Cassette

If you have a 2500 ATG with Negator Cassette, follow the procedure in this section to install the gauge tape and load the negator cassette on the gauge head.

1. Install the furnished crank assembly and lock it into the case keyhole slot using the spring-loaded screw.
2. Remove the two socket-head screws attaching the Negator Cassette to the storage sheave.
3. Remove the Negator Cassette from the gauge head by pulling it straight out.

Warning! Do not over-wind negator motor. Winding motor greater than the indicated number of turns may cause the motor to dislodge and uncoil from its pulley, causing damage to equipment and injury to personnel.

Warning! Use both hands for a firm grasp on the crank while winding motor. Tighten thumbscrew before releasing grip. The rapid unwinding of the spring could result in the crank spinning and striking the operator.

4. Grasp the crank assembly handle and unlock it from the Negator Cassette. Wind the motor clockwise. The number of turns is indicated in Table 3-15, in accordance with the level.

| Innage Tank Level (ft) | Innage Tank Level (m) | Outage Tank Level (ft) | Outage Tank Level (m) | Number of Turns (Neg. Cassette) |
|------------------------|-----------------------|------------------------|-----------------------|---------------------------------|
| 0 | 0.0 | 66 | 20.1 | 45 |
| 2 | 0.6 | 64 | 19.5 | 44 |
| 4 | 1.2 | 62 | 18.9 | 43 |
| 6 | 1.8 | 60 | 18.3 | 41 |
| 8 | 2.4 | 58 | 17.7 | 40 |
| 10 | 3.0 | 56 | 17.1 | 39 |
| 12 | 3.7 | 54 | 16.5 | 37 |
| 14 | 4.3 | 52 | 15.8 | 36 |
| 16 | 4.9 | 50 | 15.2 | 35 |
| 18 | 5.5 | 48 | 14.6 | 33 |
| 20 | 6.1 | 46 | 14.0 | 32 |
| 22 | 6.7 | 44 | 13.4 | 31 |
| 24 | 7.3 | 42 | 12.8 | 29 |

Figure 3-15: Innage and Outage Turns of the Negator Cassette

| Innage Tank Level (ft) | Innage Tank Level (m) | Outage Tank Level (ft) | Outage Tank Level (m) | Number of Turns (Neg. Cassette) |
|------------------------|-----------------------|------------------------|-----------------------|---------------------------------|
| 26 | 7.9 | 40 | 12.2 | 28 |
| 28 | 8.5 | 38 | 11.6 | 27 |
| 30 | 9.1 | 36 | 11.0 | 25 |
| 32 | 9.8 | 34 | 10.4 | 24 |
| 34 | 10.4 | 32 | 9.8 | 23 |
| 36 | 11.0 | 30 | 9.1 | 22 |
| 38 | 11.6 | 28 | 8.5 | 20 |
| 40 | 12.2 | 26 | 7.9 | 19 |
| 42 | 12.8 | 24 | 7.3 | 18 |
| 44 | 13.4 | 22 | 6.7 | 16 |
| 46 | 14.0 | 20 | 6.1 | 15 |
| 48 | 14.6 | 18 | 5.5 | 14 |
| 50 | 15.2 | 16 | 4.9 | 13 |
| 52 | 15.8 | 14 | 4.3 | 11 |
| 54 | 16.5 | 12 | 3.7 | 10 |
| 56 | 17.1 | 10 | 3.0 | 9 |
| 58 | 17.7 | 8 | 2.4 | 8 |
| 60 | 18.3 | 6 | 1.8 | 6 |
| 62 | 18.9 | 4 | 1.2 | 5 |
| 64 | 19.5 | 2 | 0.6 | 4 |
| 66 | 20.1 | 0 | 0.0 | 3 |

Figure 3-15: Innage and Outage Turns of the Negator Cassette (continued)

5. Lock the crank assembly into the case keyhole slot before releasing your grip on the handle.
6. At the gauge head, put the first hole in the tape on a pin of the sprocket close to the tape guide.
7. Rotate the sprocket clockwise to pull the tape through the guide.
8. Pull the tape around the storage sheave.
9. Fasten the 2nd hole in the tape to the tape storage sheave on the sheave pin.
10. Turn the storage sheave counter-clockwise to wind up all excess tape.
11. Reinstall the Negator Cassette with crank assembly into gauge head. Reinstall the two socket head screws. Grasp the installation crank firmly and unlock it from the case. Allow the handle to rotate to remove any additional tape slack.
12. Check the tape path between the float and the gauge head to be sure that it is not kinked or twisted.

Caution! Do not attempt to hand crank the float above (through) a floating roof. Hand-cranking the tape beyond this point on a floating roof installation can damage and snap the tape!

With a Hand Crank Gauge Head

Caution! Do not disengage the hand crank, while the float is off the bottom of the empty tank or above the surface of a product. A free fall may damage the float or the gauge. Make certain that the hand crank is disengaged when the float is returned to the tank bottom or to the surface of the product. Damage to the gauge and inaccurate measurements may result.

Caution! Do not continue to turn the hand crank after the float reaches the top of the tank, the bottom of the tank or the product level.

Caution! Do not use the hand crank for any installation that directly attaches the tape/tape cable to a floating roof. Damage to the gauge may result. The hand crank gauge head should not be used in this type of installation.

1. Ensure that the hand crank is in the engaged position. To engage, push the ratchet pawl lever up and push the crank handle hub inward until the ratchet pawl engages the ratchet gear.
2. To wind the motor, turn the crank the number of times indicated in Table 3-16, Turns to Wind Negator Motor. Turn until the motor is wound and the ratchet pawl is at mid position (engaged).

| Motor Sheave Part No. | Gauge Head Motor (Normal Application) | Turns with Float Crank (hand crank turns) |
|-----------------------|--|---|
| BA7762 | Standard: 0 - 60' (0-18m) tank range | 120 |
| BA17725 | Extra Strong: 0 - 60' (0-18m) tank range | 125 |
| BA17087 | Extra Long: 0 - 90' (0-27m) tank range | 168 |

Figure 3-16: Turns to Wind Negator Motor

3. Perform the procedure in “Install Tape in the Gauge Head” on page 50 to install the tape in the gauge head.
4. Hold the crank handle firmly and hold the ratchet pawl up.
5. Crank clockwise to lower the float to the bottom of the tank, while observing the tape travel through the elbows and gauge head.
 - There should be no binding.
6. Disengage the hand crank.
 - To disengage, hold the ratchet pawl lever up, pull outward on the crank handle hub until the gear is disengaged. Then push the ratchet pawl lever down.

Trimming the Cable at the Float in a Floatwell

Note Ensure you have completed all previous steps from your installation checklist before proceeding.

1. Check the tape/tape cable path between the float and the gauge head to be sure that it is not kinked or twisted.
2. Check that the tape/tape cable splice position is at the bottom end of the outboard elbow connection.

Caution! Splice must reside in vertical pipe throughout the total travel of the roof. If splice enters gauge head, gauge will hang up and damage will result. If splice passes over elbow sheave, the gauge may hang up or may cause the tape/tape cable to become dislodged from the sheave.

3. To adjust, loosen the screws on the cable clamp while holding on to the cable. Pull the cable through the clips while keeping the tape tension tight. When splice is in proper position, tighten the screws and release cable. The spring motor will pull the tape taut.
4. Check that the float is correctly positioned parallel to the waterline of the well, then cut off the excess cable.

Caution! Do not allow the float to fall back to the floor of the tank. Damage to the float or tank may result.

Reset the Counter

Note Ensure you have completed all previous steps from your installation checklist before proceeding.

To reset the dial and counter, remove the counter cover assembly as shown and described in this section.

Caution! Be careful not to pull up and disengage or drop the pinion gear ⁽²⁴⁾. If the pinion gear is disengaged, it may be necessary to disassemble and reassemble the counter mechanism to properly calibrate the gauge. If this becomes necessary, refer to Chapter 6, Counter Wheel Assembly on page 87.

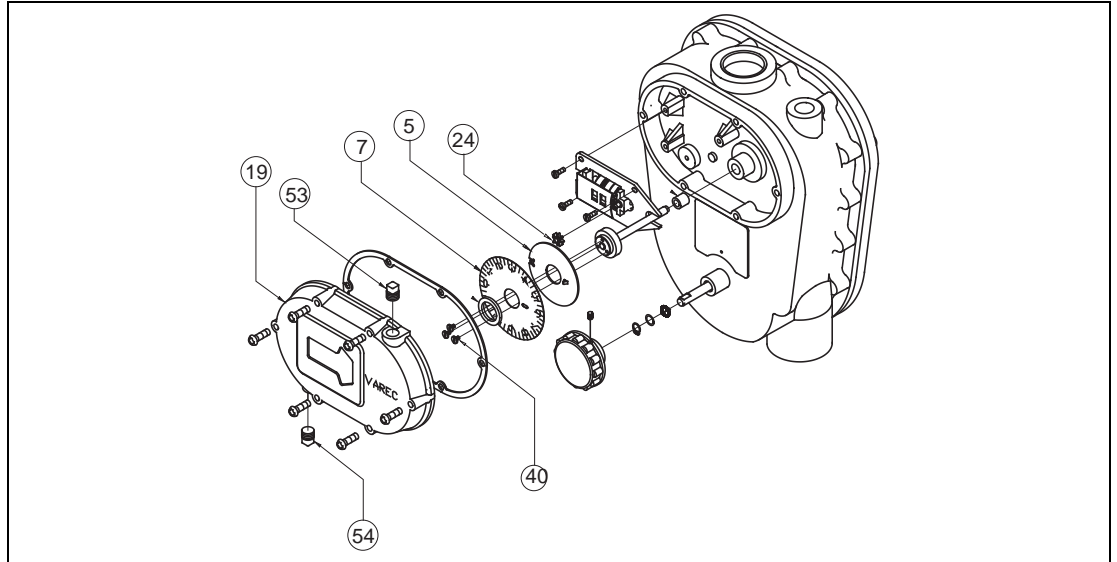

Figure 3-17: 2500 ATG Counter Cover and Assembly Parts

Note Reversible dials - English gauge heads are shipped with a dial indicating in feet, inches, and 1/16 inch. The backside of the dial is marked to indicate 1/10 ft. x 1/100 foot. The user can reverse the dial to suit.

1. Remove the counter assembly cover.
2. Rotate dial plate (7) and gear (5) until the dial plate and counters display all zeros.
3. Loosen dial plate screws (40) until the dial plate (7) and gear (5) rotate freely and independently of the hub assembly.
4. Check that the float is at zero level with the tape taut.
5. If calibration is required, proceed to the next section.
6. Tighten the dial plate screws (40), being careful to not over tighten them.

Reading the Counter

There are two different types of counters: English and Metric counters.

English counters have two counter wheels and a dial.

1. The left wheel indicates 10X Feet.
2. The right wheel indicates 1X Feet.
3. The dial is reversible.
 - a. One side is Inches & Sixteenths of an Inch.
 - i. The numbers are whole inches and the tick marks represent sixteenths of an inch (1/16"). See Figure 32 below.
 - b. The opposite side is Decimal Feet.

- i. The numbers represent 0.1 Feet and the tick marks represent 0.01 Feet. See Figure 32 below.

Metric counters have three counter wheels and a dial.

1. The leftmost wheel indicates 10X Meters (10,000 mm).
2. The center wheel indicates 1X Meters (1000 mm).
3. The rightmost wheel indicates 0.1X Meters (100 mm).
4. The numbers on the dial represent 0.01X Meters (10 mm). The tick marks on the dial indicate millimeters (mm). See Figure 32 below.
 - a. Newer dials have two digit numbers, which represent millimeters (mm).
 - b. Older dials have single digit numbers, which represent centimeters (cm).

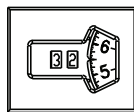

ENGLISH: FEET-INCHES-1/16"
32'-5 1/2"

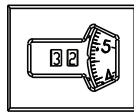

ENGLISH: DECIMAL FEET
32.46 FT

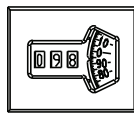

METRIC: MILLIMETERS
9894 MM

Figure 3-18: The 2500 Counter: English: Feet, English: Decimal Feet, and Metric: Millimeters

Setting Counter Spacing

The 2500 ATG's counter spacing is properly set at the factory. However, occasionally during shipping and handling the spacing can become improperly set. Therefore, the counter spacing needs to be confirmed prior to putting the 2500 ATG into service and possibly readjusted. Refer to Figure 8-3 on page 103 for an exploded view with item numbers to understand the item references below.

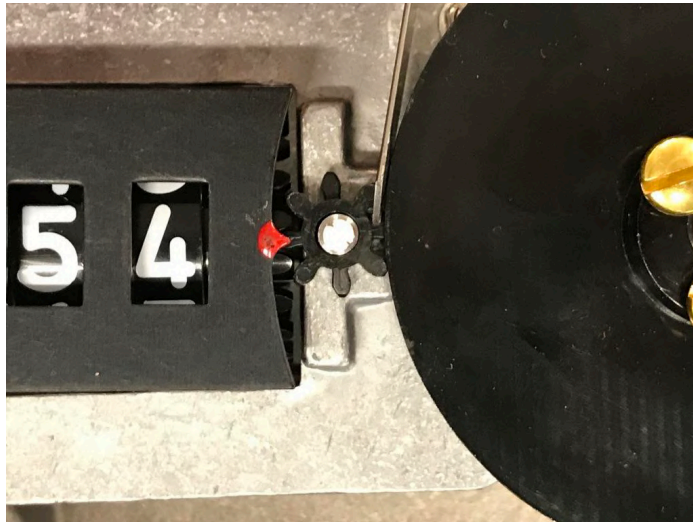

Figure 3-19: Measure counter spacing with feeler gauge at pinion



Figure 3-20: Pinion counter wheel alignment on whole numbers

1. Remove the counter cover (Item 19) with the six counter cover cap screws (Item 39).
2. Remove one of the three dial retaining screws (Item 40). Loosen the other two.
3. Remove the Dial Retainer (Item 9) and Dial Plate (Item 7). Take care not to remove or lose the pinion gear (Item 24).

4. Reach under the rightmost counter wheel (a component of Item 21) and rotate the bottom upwards towards the top of the gaugehead. This will pivot the pinion gear (Item 24) such that the lower high tooth rests firmly against the outer rim of the dial gear (Item 5).
5. Place a feeler gauge between the top pinion gear high tooth and the rim of the dial gear (Figure 3-19 above). It should measure .028" to .034" (0.71 to 0.86 mm). If so then proceed to Step 9 to calibrate and reassemble.
6. If the counter spacing was out of range, then remove the dial gear (Item 5).
7. Slightly loosen the three hex washer head counter base screws (Item 43).
8. Temporarily reinstall the dial gear (Item 5) as follows:
 - a. The rightmost counter wheel needs to be set properly on a number (not half way between numbers).
 - b. One of the short teeth of the pinion gear (Item 24) needs to mate between the counter wheel teeth. That tooth should be pointing directly to the left (9 o'clock position). (Figure 3-20 above)
 - c. Temporarily reinstall the dial gear such that the rightmost short tooth on the pinion gear (3 o'clock position) is under the rim of the dial gear and the two adjacent higher teeth straddle the outside rim of the dial gear (Photo 5885).
 - d. Using a .030" (0.75 mm) feeler gauge and following Steps 4 & 5 (above), slide the counter assembly (Item 21) to the left and right to set the pinion tooth to dial gear rim spacing to .030" (0.75 mm).
 - e. Tighten the left two counter base screws (Item 43).
 - f. Remove the dial gear and tighten the third (and final) counter base screw.
 - g. Reinstall the dial gear
9. If the gaugehead hasn't been calibrated to the actual tank level, now is a good time to do see the "Calibrate the Counter" section below.
10. Reinstall the Dial Plate (Item 7) on top of the dial gear (Item 5). Make sure that its slotted hole in the dial plate fits over the rectangular boss on the dial gear (Item 5) and that the dial plate is underneath the black counter mask with the red indicator mark (a component of Item 21).

Caution! Damage to the dial plate can occur if the rectangular boss isn't in the dial plate slot.
11. Reinstall the Dial Retainer (Item 9).
12. Reinstall the third dial retaining screw (Item 40) that was previously removed and tighten all three screws.
13. Reinstall the counter cover (Item 19), making sure the counter cover gasket (Item 6) is still in place.
14. Reinstall the six counter cover cap screws (Item 39).

Calibrate the Counter

Note These instructions apply to systems that use a hollow-shell, welded float that is 14.5 inches (368 mm) in diameter by 4.0 inches (102 mm) deep. Calibration is based upon the standard specific gravity of water (1.0). The value set on the dial plate (7) is the waterline level on the float as it contacts the bottom of the tank. Refer to the table below to determine the setting for the dial plate.

Caution! Be careful not to pull up and disengage or drop the pinion gear (24). If the pinion gear is disengaged, it may be necessary to disassemble and reassemble the counter mechanism to properly calibrate the gauge. Refer to Section “Counter Wheel Assembly” on page 87, if this becomes necessary.

Note If the dial and counter drums have not been reset to zero as described in the preceding section, perform those steps first.

Note The counter must be re-calibrated after product is placed in the tank.

Caution! Do not attempt to hand crank the float above (through) a floating roof. Hand-cranking the tape beyond this point on a floating roof installation can damage and snap the tape!

1. Determine the value at which to set the dial. You can determine the value from the table below or from specific gravity tables for the product that will be (or is) in the tank. Alternatively, use a hand gauge to determine product level.

| Gauge Head Units x Minimum Increment | Counter Drum Settings | | | Dial Setting (s.g. = 1.0) | Corresponding Measure |
|--------------------------------------|-----------------------|---|---|---------------------------|-----------------------|
| ft. & in. x 1/16 in. | - | 0 | 0 | 2 | 2 inches |
| ft. & 1/10 ft. x 1/100 ft. | - | 0 | 0 | 16.5 | 0.165 ft. |
| meters x 1/1000 M | 0 | 0 | 0 | 51 | 4 inches |

Figure 3-21: Initial Calibration Table

2. Rotate the dial to the determined value.

Note If it is necessary to disassemble the counter mechanism, refer to Figure 6-3 on page 87, or for more instruction detail, refer to section , "Counter Wheel Assembly" on page 87.

3. Tighten the dial plate screws (40), being careful not to over tighten them.
4. Observe the operation of the counter drums and dial, while slowly cranking the float to the top of the tank and then lowering it to the bottom. The counter drums and dial should rotate freely and return to the calibrated indication when the float touches the tank bottom.

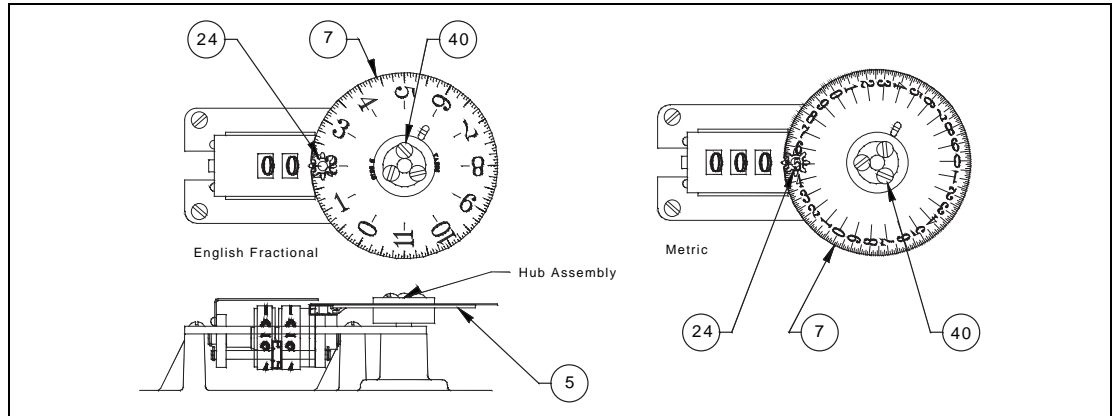

Figure 3-22: Dial Plate Adjustments

Initial Lubrication

Note Ensure you have completed all previous steps from your installation checklist before proceeding.

Caution! Gauges measuring caustic liquids require that the gauge head be oil-filled.

Failure to protect the gauge head with oil may result in damage.

Note Refer to Chapter 7, Lubrication and Oil Warnings for recommended oil.

1. Apply a light oil to the elbow sheave.
2. If the gauge head is not going to be filled with oil, apply a light oil to the tape sprocket and storage sheave.
3. If the gauge head is to be filled with oil, reassemble the gauge head, then fill with oil. For most service, Varec recommends filling the gauge head with oil to reduce wear and prolong the service life.

Note To fill the counter assembly side of the gauge head with oil, it is necessary to change the bottom NPT condensate drain plug. Replace it with a solid 1/4" NPT plug or reverse the solid top plug with the bottom plug. Fill the hole in the condensate drain plug with RTV 737 sealant.

4. If your installation requires oil seals on the tape-run conduit elbows refer to Chapter 4, Oil Seal Installation on page 71.

Install a Transmitter and Replace all Covers

Note Be sure to read Chapter 2, General Preparation before proceeding with this installation. Ensure you have completed all previous steps from your installation checklist before proceeding.

Caution! Do not store the installation crank and thumbscrew in the gauge head, but keep them at a storage area for future use.

Caution! Do not over-torque the back cover bolts.

1. Remove the installation crank and thumbscrew.
2. When a transmitter or other auxiliary equipment is to be installed, ensure the equipment hole size and bolt pattern matches the 2500 ATG. Remove and discard the cap and red fiber washers from the back cover. Each transmitter's slotted coupling should properly engage the sprocket sheave auxiliary drive pin. Use the cap screws to attach the transmitter to the back cover. Refer to the transmitter documentation for detailed installation, configuration, and operation.

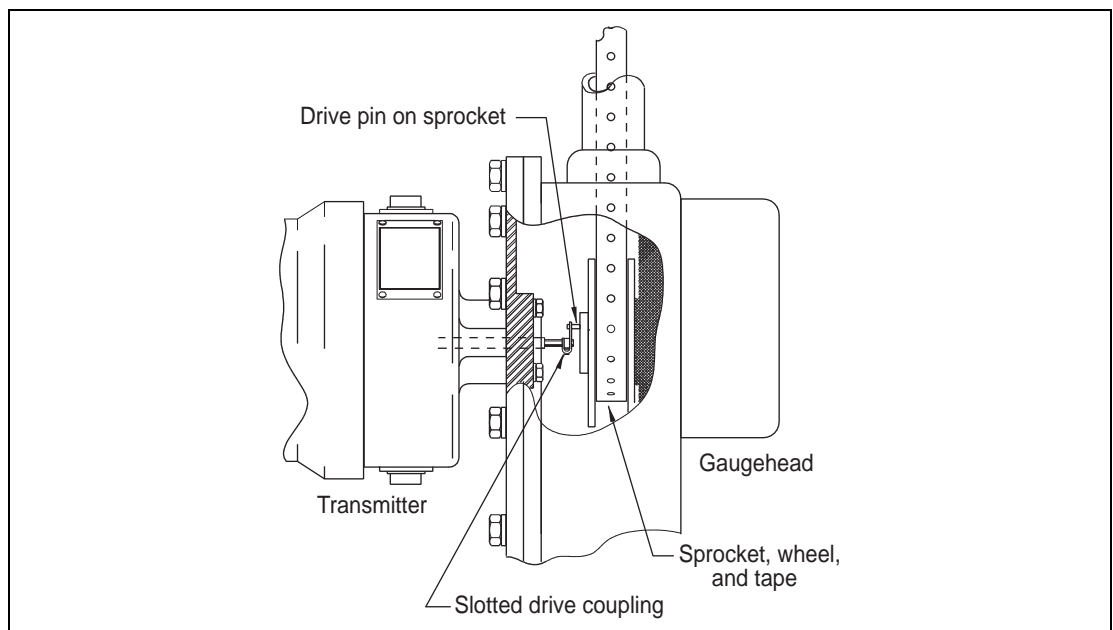

Figure 3-23: Transmitter Installation on a 2500 ATG

Note The use of auxiliary units not manufactured or supplied by Varec will void any Varec warranty and will relieve Varec of any obligation to service the product under warranty.

3. Replace the back cover and its gasket.
4. Torque the back cover bolts to 6 ft-lb. Do not over-torque!
5. Replace the bolts, gaskets, and covers on the elbows.
6. Close the tank manholes and inspection covers.
7. Check the operation of the auxiliary unit as appropriate

Initial Operation

Caution! Initial filling of the tank must be at a reduced rate of flow, until the float travel and dial operation are verified. This checks that the 2500 ATG was installed correctly and prevents possible damage to the gauge system.

Caution! Floating Roof Tanks: On floating roof tanks this is particularly important because the tape travel has not been checked during the installation.

1. Station an observer at the gauge head.
2. Begin filling the tank to raise the float several feet (about three feet or one meter) from the bottom.

Caution! Do not release the checker knob and allow the springs to return the mechanism. Over time the springs will break and jam the gauge.

Caution! Do not turn the operation checker knob on systems that have no float and that are directly connected to a floating roof.

3. Turn the operation checker knob on the front of the gauge head of non-crank types a quarter-turn clockwise to lift the float slightly. Check that the display registers the movement.

Caution! For hand crank gauge heads, do not disengage the crank while the float is above the surface of the liquid. Do not allow the float to free fall. Damage to the system may result.

4. For hand crank gauge heads, engage the crank to make the check, then disengage the crank. To engage the crank, hold the ratchet pawl, in the disengaged position (upward) and push in on the hub of the crank assembly. To disengage the crank, make certain the float is on the surface of the liquid, by rotating it slowly until the counter stops. Do not continue to crank!
5. To disengage, hold the ratchet pawl lever up, pull outward on the crank handle hub until the gear is disengaged. Then push the ratchet pawl lever down.

Note If the tape becomes slack with the float on the surface, the tape may slip off the elbow pulley, the tape storage sheave, or the tape keeper. If this occurs, refer to Chapter 9, Troubleshooting.

6. Continue filling the tank to the desired level.

7. Hand gauge the product and compare the measurement with the display. If they do not coincide, refer to Chapter 3, Reset the Counter.

4 In-Service Installation Procedures

Note Before installing your 2500 ATG, read and review all safety precautions on page ii of the preface to this document. Continuing with installation according to the instructions in this manual presumes you have reviewed these safety precautions.

Note Refer to Chapter 2, Identifying Your Installation Type before proceeding.

Warning! Make certain that the tank has been leak and pressure tested as appropriate for the liquid stored. Observe appropriate safety precautions in flammable or hazardous liquid storage areas.

Warning! Do not enter a tank that contains hydrocarbons, vapors, or toxic materials, until a gas-free environment is certified. Carry breathing equipment when entering a tank where oxygen may be displaced with carbon dioxide, nitrogen, or other gases or toxic fumes may be present.

Warning! The mechanical connections between the guide cables, the float, the tape, and the gauge head provide a resistance to ground that is adequate for the safe electrical drain of electrostatic charges that may accumulate in the tank and the product. Worker activity and worker clothing may accumulate electrostatic charges on the body of a worker. Care should be used in flammable environments to avoid the hazard. Observe American Petroleum Institute (API) Recommended Practice 2003 or other appropriate industry or Military Standard.

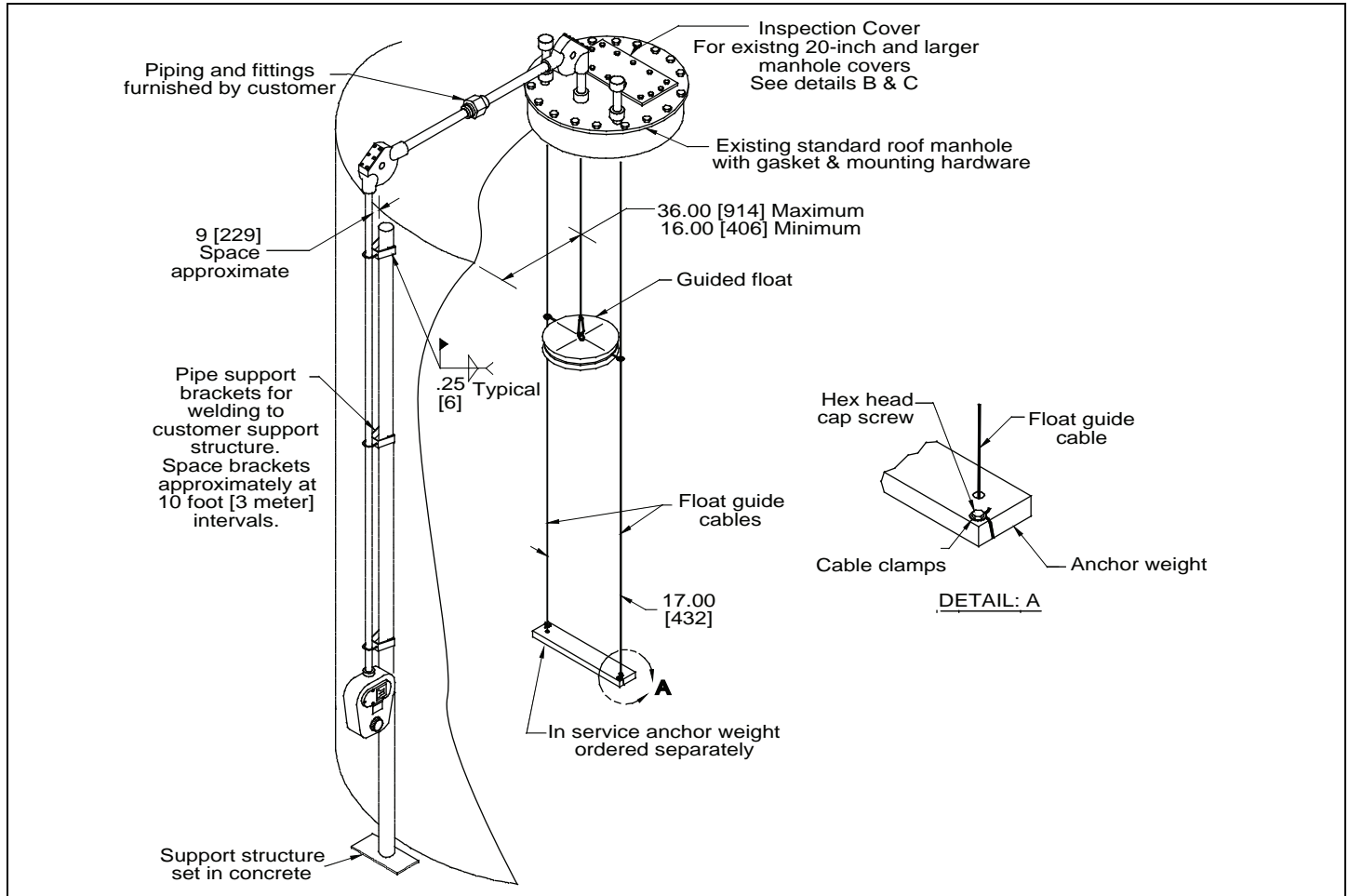

Figure 4-1: Typical In-Service-Tank Installation with Manhole, Inspection Hatch, and Independent Pipe Support Structure. Detail "A" shows in-service bottom anchor.

Negator Cassette Installation

Varec's negator cassette is a fully enclosed design to safely contain a damaged or failed negator motor. It will extend negator motor life by keeping pipe scale and debris off the negator motor. The cassette provides quick and easy change out of any future negator motor failures.

Caution! Damage to equipment may result if this precaution is disregarded.

Warning! Direct injury to personnel or damage to equipment which can cause injury to personnel may result if this precaution is not followed.

Disassembly

Perform the following steps to prepare the gauge head for installation of the negator motor cassette. For part number reference, refer to Figure 8-1 on page 101.

1. Note and record gauge-level reading.
2. Vent all pressure from gauge head.
3. If the gauge is oil-filled, drain the oil.

Warning! If the negator motor is broken, the broken pieces can cause injury. Whenever the back cover of the gauge head is removed, stand away as the last bolt is removed. Wear gloves and safety glasses.

4. Remove 16 back cover bolts ⁽³⁸⁾ and back cover ⁽¹⁷⁾ with any auxiliary equipment attached.
5. Attach the original installation crank ⁽⁵⁹⁾ provided with the gauge to the tape storage sheave.

Warning! The rapid action of the spring could result in the crank spinning and striking the operator or damaging equipment. Use a firm grasp on the crank. Tighten thumbscrew before releasing grip.

6. Remove the outboard sheave elbow cover.
7. Turn the installation crank clockwise to unwind the tape from the storage sheave.

Caution! Be careful to insure that the tape does not kink and that it remains clean.

8. While unwinding the tape in the gauge head, withdraw the tape at the outboard sheave elbow.
9. When all tape is removed from the storage sheave, turn the installation crank slowly counter clockwise to wind the negator spring motor onto the motor storage sheave.
10. Detach the negator motor ⁽⁴⁸⁾ from the storage sheave by loosening the securing screw ⁽⁵⁷⁾.
11. Remove the negator motor ⁽⁴⁸⁾, bushings, washers, and shims.
12. Remove the storage sheave assembly ⁽⁸⁾, bushings, washers, and shims.

Assembly

Perform the following steps to install the gauge head:

1. Install a Teflon washer if needed ⁽⁴⁾, a shim washer ⁽⁴⁵⁾ and the new storage sheave ⁽⁵¹⁾ over the lower gauge head shaft ⁽¹⁰⁾.

Note In the next step, the alignment of the sprocket sheave to the tape storage sheave is critical for proper operation of the gauge.

2. Adjust the number of shims to bring the sheaves into the specified alignment as shown on Figure 4-2.

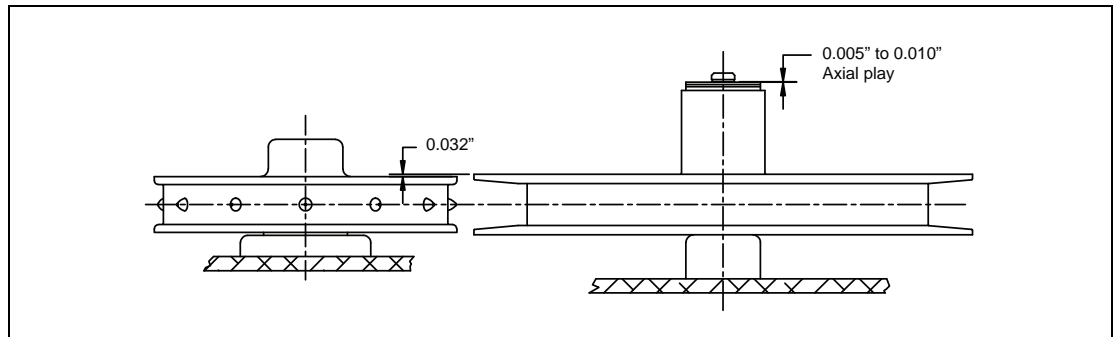

Figure 4-2: Sheave Alignment

3. Complete the installation of the storage sheave by installing shims (45), a Teflon washer if needed (4), and a flat washer (44).
4. Test that the sheave turns freely with axial play within 0.005" to 0.010" (0.13 to 0.25 mm). Lateral offset between the two sheaves should not exceed 0.032" (0.81 mm).

Note If play is excessive, add shims (45) to remove play.

5. Attach the end of the tape over the sheave pin (28) and while wearing gloves, wind the tape onto the sheave assembly (18) as an assistant provides some tension on the tape to keep it from kinking or twisting.
6. Prior to installing the cassette (50) into the gauge head, use the crank assembly (52) to wind the cassette clockwise the number of turns indicated in Chapter 3, Install Tape in the Gauge Head on page 50. The counter reading should match the product level.
7. Lock the crank assembly by setting the spring-loaded screw into the keyhole slot in the cassette.
8. With the crank assembly locked in position, install the cassette into the gauge head.
9. Install the two socket-head screws (49) to secure the cassette to the storage sheave.
10. Grasp the crank assembly handle firmly, and pull the spring-loaded screw to unlock the handle. Rotate the handle to take up any slack in the tape.
11. Remove the crank assembly.
12. Check the tape path to insure that the tape is not twisted or kinked.
13. Test the operation of the gauge by rotating the gauge check knob $\frac{1}{4}$ turn clockwise and releasing.
 - The level indicated on the counter should return to the same reading $\pm \frac{1}{8}$ " (3 mm).

Caution! Do not attempt to operate the gauge check knob if the tape/cable is attached to a floating roof to prevent damaging or breaking the tape.

14. Install the outboard sheave elbow cover.
15. Install the back cover and any auxiliary equipment.

Note The slotted coupling on any auxiliary equipment must engage the drive pin on the sprocket sheave.

16. Check the level indication on the gauge and compare it with the level reading recorded before disassembly.
17. If necessary, adjust the gauge level reading to match the pre-disassembly reading.
18. To complete the assembly, refer to Chapter 3, Initial Lubrication.
 - That section gives instructions to reset and calibrate the counter, install transmitters and other auxiliary equipment, and replace the back cover.

Note Torque back cover bolts to 6 ft-lb (8.1 J). Do not over torque!

19. Refill gauge head with oil if required.
20. Close the tank inspection hatches and manholes.

Oil Seal Installation

For tank configurations that include optional oil seal accessories, refer to these illustrations and perform the installation procedures included in this section.

27-inch Water column operating pressure oil seal

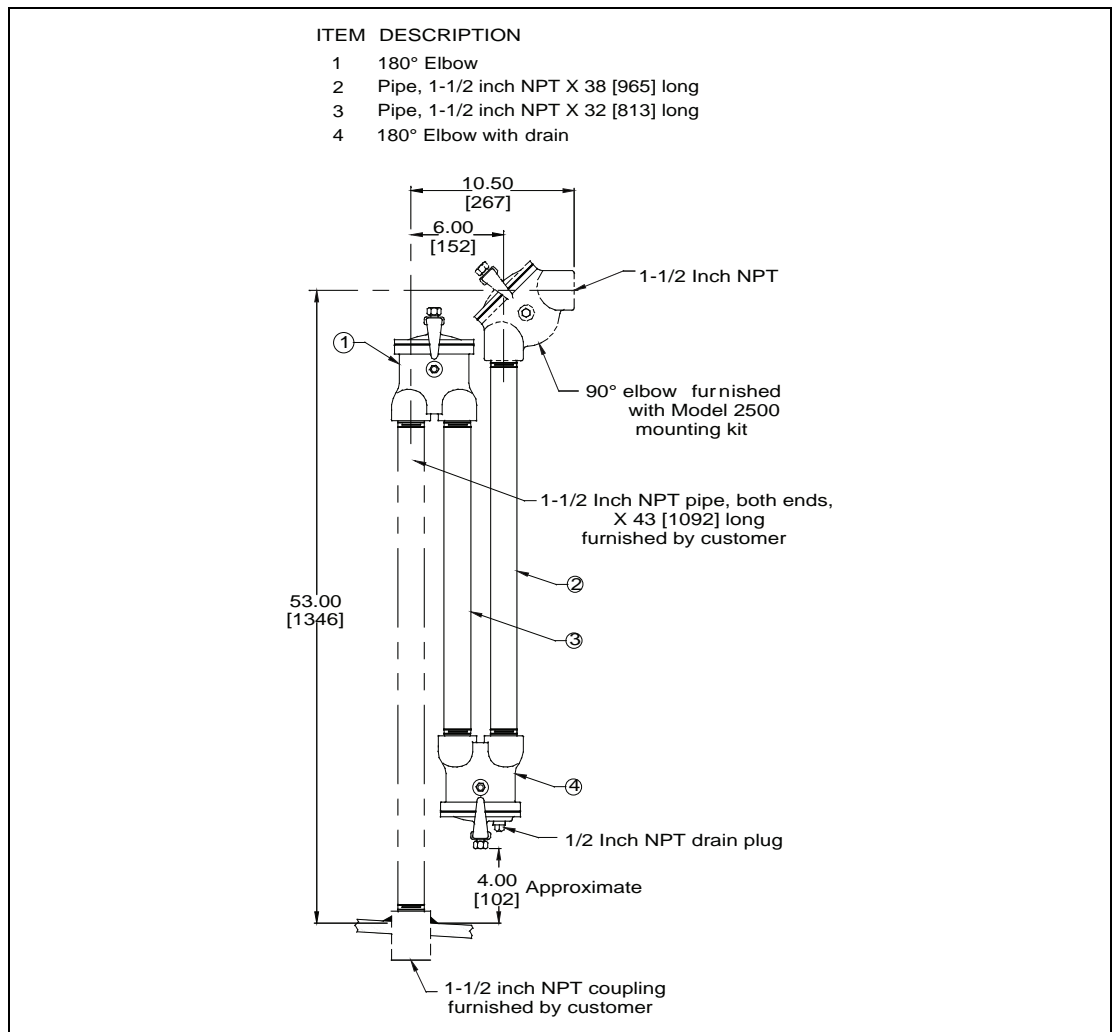

Figure 4-3: Installation of Oil Seal, 27-inch Water Column Operating Pressure Oil Seal

1. Apply appropriate pipe compound and install short pipe (3) into 180 degree elbow (1).
2. Apply pipe thread compound and install 180 degree elbow (4) onto short pipe (3).
3. Apply pipe thread compound and install long pipe (2) into elbow (4).
4. Apply pipe thread compound and install 90 degree elbow supplied with gauge kit onto long pipe (2).
5. Complete the assembly to the user furnished 1.5 inch pipe (DN40).
6. Adjust the assembly to provide the tape/tape cable path illustrated.
7. Proceed with the remainder of the tank installation to the paragraph Initial Lubrication, then fill the oil seal as follows:
 - a. Remove the cover from 90 degree elbow.
 - b. Fill the short pipe to halfway with oil.

Note To drain the oil, open the plug in 180 degree elbow (4).

8.5-inch Water Column Operating Pressure Oil Seal

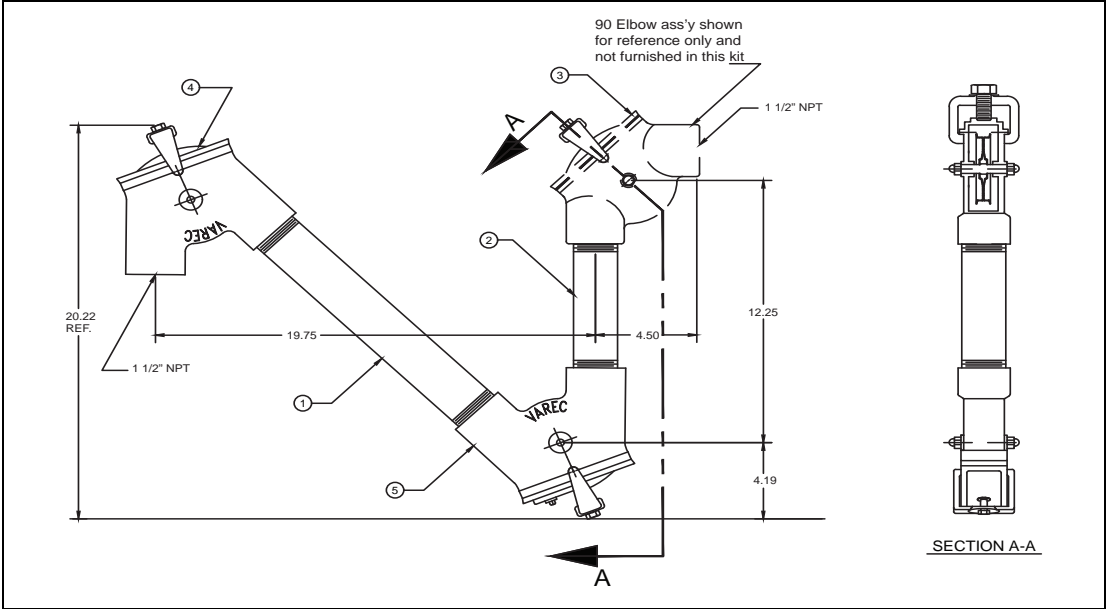

Figure 4-4: Oil Seal, 8.5-inch Water Column Operating Pressure Oil Seal

1. Apply appropriate pipe thread compound and install long pipe (1) into 135 degree elbow with bottom drain (4).
2. Apply pipe thread compound and install short pipe (2) into 135 degree elbow with bottom drain (4).
3. Apply pipe thread compound and install 135 degree elbow (3) onto long pipe (1).
4. Apply pipe thread compound and install 90 degree elbow supplied with gauge kit onto short pipe (2).
5. Adjust the assembly to provide the tape/tape cable path illustrated.
6. Provide 1.5 inch pipe (DN40) installation, as required.
7. Proceed with the remainder of the tank installation to the paragraph Initial Lubri-
cation, then fill the oil seal as follows:
 - a. Remove the cover from 90 degree elbow.
 - b. Fill to halfway in the short pipe.

Note To drain the oil, open the plug in 135 degree elbow (4).

Inspection Hatch and Manhole Cover

Varec recommends the installation of a manhole or inspection hatch, if there is not already one located within arm's reach of the tape pipe location.

Inspection Hatch

1. Remove the cover to a safe welding location.
2. Cut a rectangular hole 6.00 inches x 15.75 inches (152 mm x 400 mm) in the cover.
3. Cut a 2.50-inch (63.5 mm) diameter hole in the cover to carry the tape drop pipe.
4. Cut two 1.75-inch (44.5 mm) diameter holes in the cover to carry the top guide cable anchors.
5. Disassemble the inspection cover and gasket from the frame.
6. Weld the inspection cover frame to the manhole cover.
7. Weld the guide cable anchor nipples and the tape drop pipe coupling in place. Make certain that they are vertical and correctly centered.
8. Carry the modified cover assembly back to the tank site. Orient the modified manhole cover as shown, and reinstall.
9. Refer to the appropriate tank configuration figure to check the tank configuration and install the tape piping and gauge head.

Manhole Cover

This section gives instructions to install 226 20-inch and 24-Inch Manhole Covers with API Drilling.

Install 226 20 inch (Part Number BM3443) and 24 inch (Part Number BM3607) manhole covers with API drilling.

1. Remove the existing manhole cover.
2. Separate the 226 cover in two by removing the bolts.
3. Install the cover half with the pipe coupling to the top of the tank.
4. Refer to the appropriate tank configuration figure to check the tank configuration and install the tape piping and gauge head.

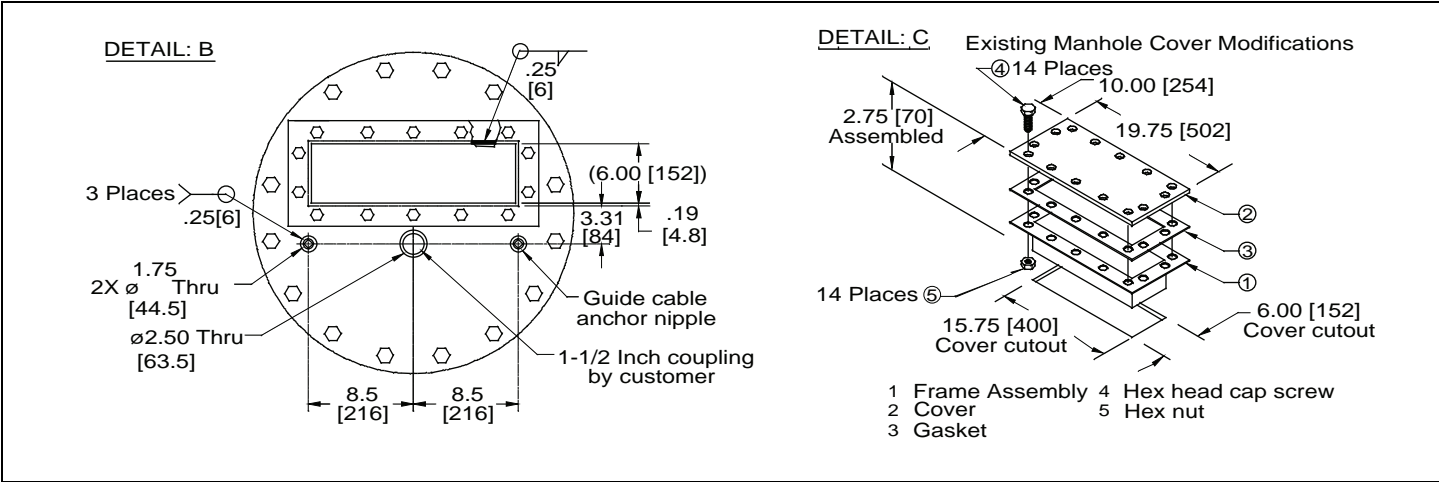

Figure 4-5: Manhole Cover and Inspection Hatch

Guide Wire Bottom Anchors

Varec supplies an anchor bar for in-service installations (Part Number BA4481) that must be ordered separately. It is for normal service only. The guide cables fasten to the anchor bar with cable clamps (see Figure 3-6). For severe or extreme service installations, contact Varec. The Bottom Anchor Bar is made of solid metal and weighs 50 lbs. (22.6 kg).

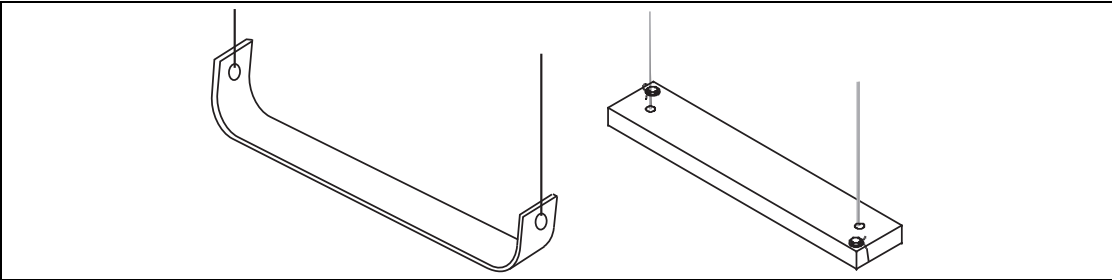

Figure 4-6: Typical Anchor Installment with Cable Clamps on Left View.

In-service Float & Guide Wire Installation

1. Refer to appropriate tank configuration and if required install top anchors less long nipple and cap.
2. Thread the float guide cables into the tank through the top anchor fittings and pull the ends back through the inspection hatch.

3. Fasten the bottom anchor to the guide cables (see Figure 4-6) and lower the anchor slowly through the inspection hatch into the tank.
4. When anchor bar is resting on tank bottom, remove cable slack by hand. Tighten cable locking nut to secure cable in place.
5. Tighten the adjustment nut until the guide cable is tensioned by the spring. Trim excess cable.
6. Use pipe thread compound and install top anchor nipples and cap.

Warning! Whenever the back cover of the gauge head is removed, stand to one side as the last bolt is removed. If the negator motor spring is broken, the broken pieces may cause injury when the cover is removed.
7. Remove the back cover and gasket from the gauge head.
8. Remove the bolts, covers, and gaskets from the elbows.
9. Apply pipe thread compound and attach the gauge head to the exterior vertical pipe. Position it for convenient reading. The weight of the gauge head is supported by the pipe and brackets.
10. Using the box that the tape came in, pull the tape out like a measuring tape. This keeps the tape from becoming twisted or kinked. At the elbow on the tank entry pipe, unroll one or two turns of the perforated tape and start to feed it into the horizontal pipe.

Caution! If the tape binds in the pipe during threading, check the pipe for corrosion and other obstructions. Check the tape to make certain that it did not kink. Friction in the pipe will affect accuracy and may break the tape.
11. Install the gauge tape and 'U' piece to the tape connector with the tape clamps and screws provided.

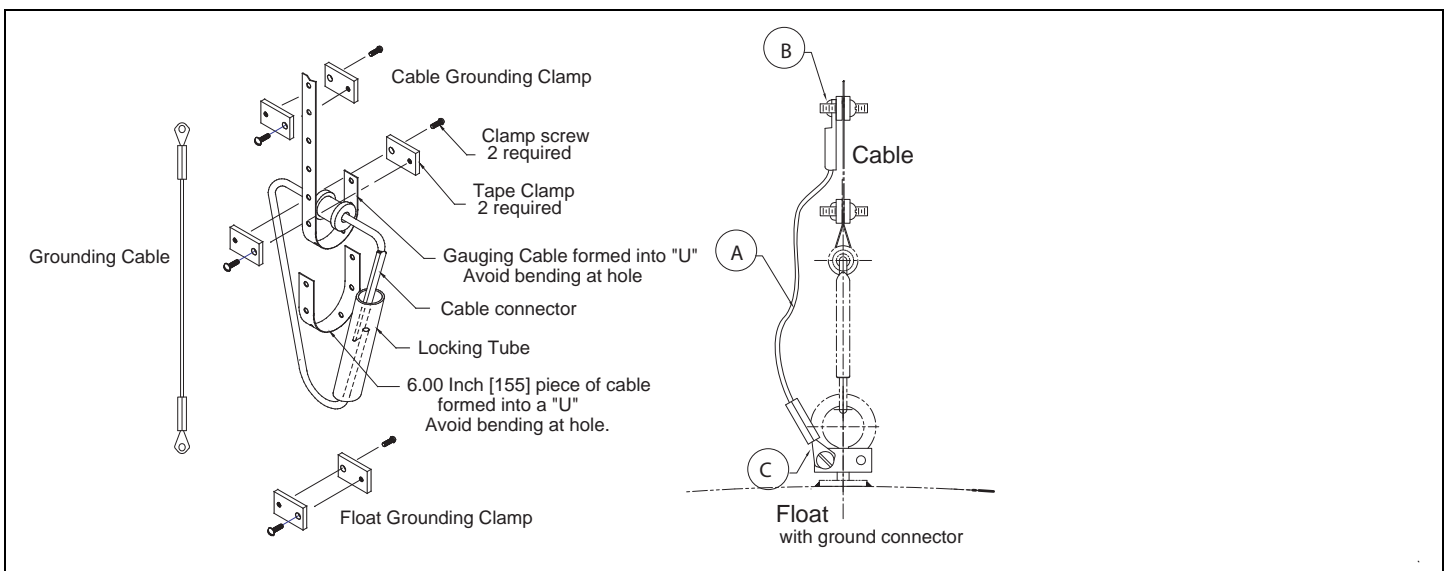

Figure 4-7: Tape Clamp Assembly

12. Attach the tape connector to the float, pass it through the hatch and attach the eyes to the guide cables.

Caution! Do not allow the float to fall back to the floor of the tank! Damage to the float or tank may result. If necessary, use an assistant to help secure the float so it does not fall.

13. Lower the float until it is hanging from the tape. Inspect the tape and cables for twists and kinks. Make sure that the cables are parallel, then lower the float to the surface of the product.
14. Make sure there is sufficient slack tape inside the tank to allow float travel to the tank bottom (check reference mark previously made). Trim the tape about 6 feet (1.8 M) from the bottom of the gauge head.
15. Proceed per instructions in Chapter 3, Install Tape in the Gauge Head on page 50 depending on the model.
16. Make a hand gauge measurement of the tank product level. Use the bench mark reference to calibrate the hand gauge. Use extra care to make certain that this measurement is accurate, because the accuracy of the automatic gauge depends upon it.
17. Refer to appropriate tank configuration to reset the gauge, then use the hand gauge measurement to set the current product level.

Note To fill the counter assembly side of the gauge head with oil, it is necessary to change the bottom NPT condensate drain plug. Replace it with a solid 1/4"-NPT plug or reverse the top solid plug with the bottom plug. Fill the hole in the condensate drain plug with RTV 737 sealant.

5 Operation

Caution! Do not release the checker knob and allow the springs to return the mechanism. Over time the springs will break and jam the gauge.

Caution! Do not turn the operation checker knob on systems that have no float and that are directly connected to a floating roof.

1. For non-crank gauge heads, use the operation checker knob to check gauge operation. Turn it clockwise one-quarter turn, while observing the display.

Caution! For hand crank gauge heads, do not disengage the crank while the float is above the surface of the liquid. Do not allow the float to free fall. Damage to the system may result.

2. For hand crank gauge heads, use the crank to check gauge operation (refer to the initial operation paragraphs above). If the float is not on the surface of the liquid, slowly rotate the crank clockwise, while watching the display. When the counters stop, do not continue to crank.

Note If the tape becomes slack with the float on the surface, the tape may slip off the elbow pulley, the tape storage sheave, or the tape keeper. If this occurs, refer to Chapter 9, Troubleshooting.

3. Turn the crank counter-clockwise to raise the float about 2 inches (51 mm) above the product, then lower it back to the surface. The float should not be left on the surface of products that are agitated. Raise it to the tank top in this situation, and latch the ratchet pawl.

6 Gauge Head Disassembly and Re-assembly

Use of the maintenance kits requires that the user understand the disassembly and reassembly of the gauge head to replace parts.

Gauge Head Disassembly

Figure 6-1 is key to understanding the disassembly/reassembly procedure. The small numbers in parentheses (for example, (12)), refer to the item numbers in this figure. References in the following procedures are directed to this figure, unless otherwise indicated.

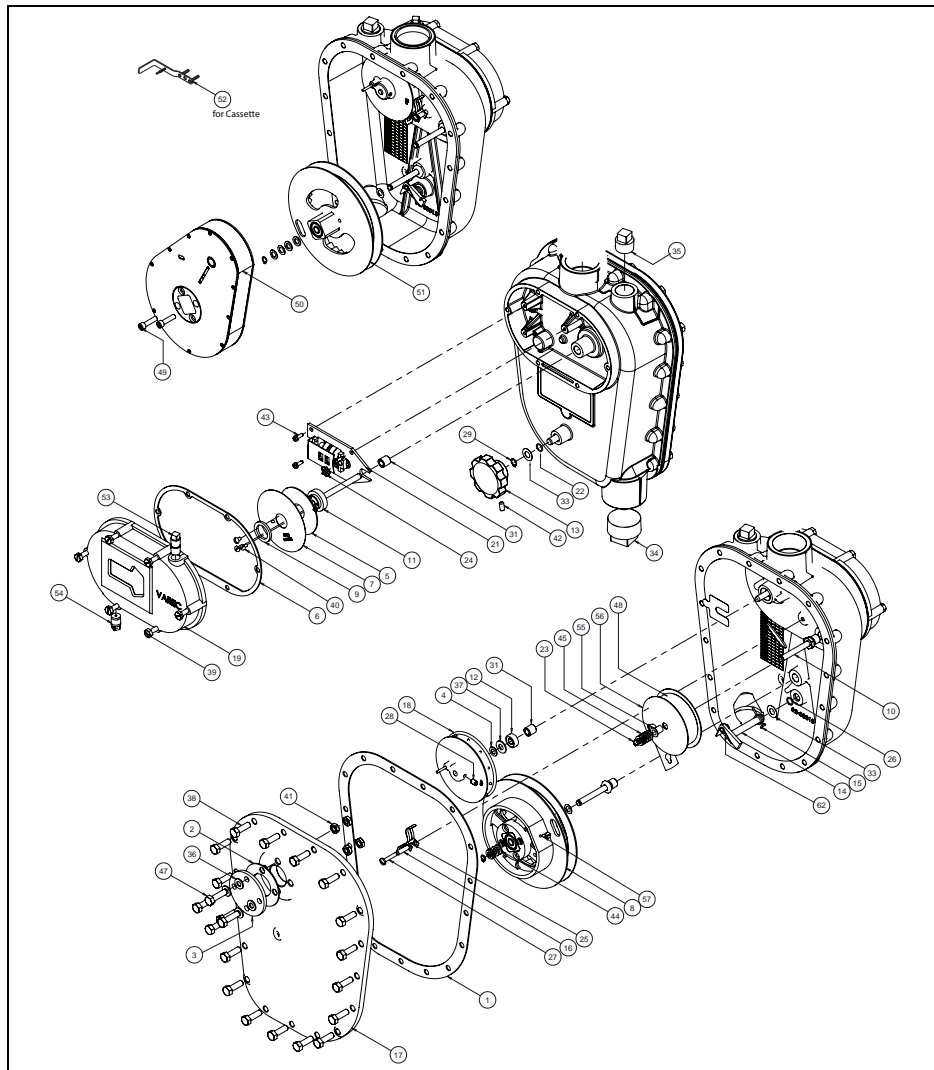

Figure 6-1: 2500 ATG (Type C) Gauge Head Spare Parts

Perform these steps to disassemble the gauge head.

Note Disassemble the gauge head only as far as needed to replace worn or defective parts.

Warning! Vapors and possible flammables! Make certain that the tank is empty and not in service. Observe appropriate safety precautions in flammable or hazardous liquid storage areas. Do not enter or access a tank that has contained hydrocarbons, vapors or toxic materials until a gas-free environment is certified. Carry breathing equipment when entering or accessing a tank where oxygen may be depleted with carbon dioxide, nitrogen or other gases.

Warning! Electrostatic Charge! Worker activity and worker clothing may accumulate electrostatic charges on the body of a worker. Care should be used in flammable environments to avoid this hazard. The mechanical connections between the guide cables, float, tape, and gauge head provide an electrical resistance path to ground that is adequate for the safe electrical drain of electrostatic charges that may accumulate in the tank and product.

1. If the gauge head is oil-filled, drain the oil.

Warning! Broken motor spring parts can cause injury! Whenever the back cover of the gauge head is removed, stand to one side as the last bolt is removed. If the motor spring is broken, the broken pieces may cause injury when the cover is removed.

2. Vent all pressure from the gauge head.
3. Remove the seventeen back cover bolts, back cover, and back cover gasket (1).
4. If accessory equipment is attached to the gauge head, disconnect and remove.
5. Attach the installation crank.
6. Open an inspection hatch or manhole for access to the float.

Warning! The rapid unwinding of the motor spring could result in the crank spinning and striking the operator. Use a firm grasp on the crank. Tighten thumbscrew to lock tape storage sheave before releasing grip.

Caution! Allowing the float to fall to the tank floor will likely damage the float. Do not allow the float to fall to the tank floor.

7. Pull the float to the top of the tank while maintaining tape tension, so that the tape feeds slowly back into the gauge head.
8. Secure the thumbscrew.
 - For Standard Model, tighten thumbscrew to lock the tape storage sheave. (see Figure 3-1, item 3). For the Cassette Model, align the locking pin with the keyhole.
9. Secure float to top of tank with secondary wire.

Caution! Allowing the float to fall to the tank floor will likely damage the float. Do not allow the float to fall to the tank floor.

10. Disconnect the perforated tape from the float connector.
11. Attach a pull string to the tape to facilitate installing a new tape.

12. Loosen the thumbscrew and slowly retract the tape into the gauge head.

13. Unwind the motor spring onto the motor storage sheave (Figure 6-2).

Caution! When unsecured, the perforated tape can retract up into the conduit where it cannot be reached. If you remove the gauge head, secure the end of the tape so it cannot retract up into the conduit. Use care to not kink or bend the tape.

14. You can now remove the gauge head from the conduit and complete the rest of this disassembly at the workbench.

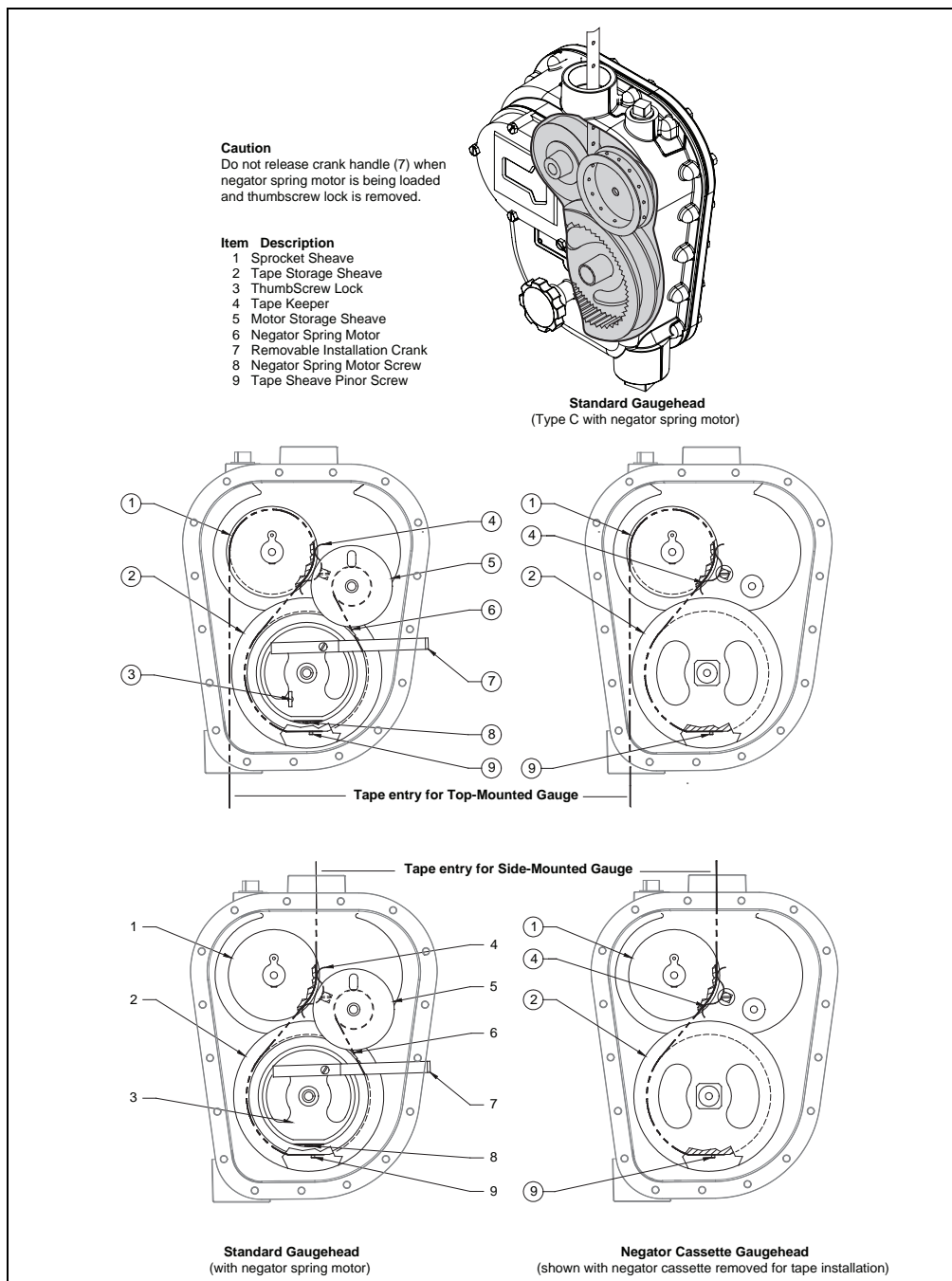

Figure 6-2: Tape Routing

15. Loosen the motor spring screw (Fig. 3-1, item 8) and detach motor spring.

16. Remove retaining ring (23), washer (44), and shim washers (45) from motor shaft.
17. Remove motor storage sheave assembly (48) as a unit.
18. Remove retaining ring (23), washer (44), and shim washers (45) from tape storage sheave shaft.
19. Remove tape storage sheave assembly as a unit.

Caution! Do not remove the sheave shafts! The sheave shafts are pressed into place and retained with a permanent adhesive compound.
20. Loosen sprocket sheave set screw (28), and remove sprocket sheave assembly (18), Teflon washer (4), shim washers (45), and washer (37).
21. Remove tape keeper assembly, which includes screw (27), post (16), and spring (25).
22. Remove six counter cover screws (39), counter cover assembly (19) and counter cover gasket (6).
23. Remove three dial retainer screws (40), dial retainer (9), and dial (7).
24. Remove the dial gear (5).
25. Remove the pinion gear (24).
26. Remove three counter assembly mounting screws (43) and counter assembly (21).
27. Remove counter shaft assembly (11) and any shim washers if needed (45).
28. Loosen gauge check knob set screw (42). Remove gauge check knob (13), grip ring (29) and shim washer (33).
29. Remove gauge check assembly (14), shim washer (33), and gauge check spring (15).
30. Remove Viton o-ring (22) on outside of gauge check boss.

Caution! Do not remove the Teflon o-ring before assessing the need to replace it. Do not reuse the Teflon o-ring if it is removed. The gauge check knob shaft Teflon o-ring (26) on the inside of the gauge head is pressed into place with a special setting tool. If replacement is required, call Varec for maintenance.
31. Remove Teflon o-ring (26) only if gauge head showed signs of leakage.

Caution! Do not remove the counter shaft seal before assessing the need to replace it. Do not reuse the counter shaft seal if it is removed. The counter shaft seal (12) is pressed into place. If replacement is required, call Varec for maintenance.

Note Do not remove the bushings from the counter shaft. The counter shaft brass bushings are pressed into the bore with special press fixtures.
32. Clean the disassembled gauge head and any parts that will be reused with a common automotive type spray or dip degreaser. Clean and wipe dry in accordance with the directions of the product used.

Gauge Head Assembly

Unless otherwise labeled, numbers in parentheses, (12) for example, refer to the item callout numbers on Figure 6-1 or Figure 6-2.

Perform the following steps to reassemble the gauge head. When white silicon grease is called for, use Dow Corning® #4 or equivalent.

Note Generally, assembly is performed in the reverse order of disassembly.

1. If counter shaft seal (12) is being replaced, use a clean, small, paint brush, and apply white silicone grease to the gauge head body seal recess.
2. Carefully press the counter shaft seal into place with cavity facing outwards.
3. If gauge check knob Teflon o-ring (26) is being replaced, lubricate o-ring with white silicone grease.
4. Carefully install the gauge check knob o-ring into the inside gauge head body recess.
5. Lubricate Viton o-ring (22) with white silicone grease, and carefully insert it into the outside gauge head body groove.
6. Assemble gauge check hair spring (62) and shim washer (33) on the gauge check assembly (14).
7. Lubricate the shaft (60) with white silicone grease, and insert it into the body.
8. Install shim washer (33) and grip ring (29) to the external shaft projection of the gauge check assembly (14).
9. Place gauge check knob (13) with set screw (42) on the external shaft projection of the gauge check assembly (14).
10. Tighten set screw, making sure it contacts the flat edge on the shaft.
11. Turn the knob in ¼-turn intervals to ensure smooth operation.
12. Replace any previous shim washers (45) on counter shaft assembly (11) and brush the shaft with white silicone grease. Install counter shaft assembly into the body.
13. Place counter assembly (21) on supports and loosely install three mounting screws (43). Do not tighten the screws.
14. Align counter assembly wheels to zero.
15. Install pinion gear (24) on counter base shaft, locating the 8-tooth side of the gear nearest the counter base. Mesh the short tooth of the pinion gear into the counter wheel gear.
16. Place dial gear (5), with registering tab downward, on the counter shaft assembly (11).
 - If the dial gear is below the top of the pinion gear, add shim washers (45) under the counter shaft assembly (11) as required. If the dial gear is higher than the pinion gear, remove shim washers from under the counter shaft assembly. If no shim washers are present, lightly tap the counter shaft assembly with a

rubber mallet so that the dial gear and the pinion gear are level within 0.010" (0.25 mm).

17. Adjust the dial gear (5) and the counter assembly (21) for a clearance of approximately 0.010" (0.25 mm) between the pinion gear (24) and the dial gear (5).
 - These two gears should engage securely, but without any binding. Rotate the dial gear to check that all gears mesh smoothly and that the counter wheels operate correctly.
18. Tighten the three screws (43) mounting the counter assembly.
19. Slip the dial (7) under the red pointer of the counter assembly and onto the hub. Rotate the dial until the tab from the dial gear (5) registers with the slot in the dial.
20. Install dial retainer (9) on dial (7) and secure it with three screws (40).
21. Place washer (37) and Teflon washer (4) on the counter shaft assembly (11).
22. Place the sprocket sheave assembly on the counter shaft assembly (11).
23. Place the tape storage sheave assembly on the lower shaft.
24. Place the motor storage sheave assembly (48) on the upper right shaft.
25. Align the motor storage (48) and the tape storage sheave assemblies. Ensure that the bottom of the motor storage sheave flange is 0.040" to 0.060" (1 to 1.5 mm) clear of the top surface of the tape storage sheave. Adjust height by using shim washers (45) as required.
26. Align the groove center line of the sprocket and the tape storage sheave assemblies. Ensure that the top surface of the sprocket sheave flange is 0.030 to 0.040" (0.75 to 1 mm) below the top surface of the tape storage sheave flange. Adjust height by using shim washers (45) as required.
27. When properly aligned, tighten the set screw (28) in the sprocket sheave assembly (18).
28. Test that the counter assembly (21) functions properly with no axial play in the counter shaft and sheave assemblies.
29. Remove the motor storage sheave assembly (48) from the gauge head.
30. Assemble tape keeper assembly (16) containing items 27, 16, 28. Apply Loctite #262 or equal to screw threads, and thread assembly into the gauge head body.
31. Adjust the tape keeper spring for a clearance of 0.020" to 0.030" (0.5 to 0.75 mm) against the sprocket sheave assembly.
32. Place the motor storage sheave assembly (48) back into the gauge head.
33. Secure the tape storage sheave assembly with retaining ring (23). Use washer (44) and shim washers (45) as required.
34. Test that the sheave turns freely with less than 0.005" (0.13 mm) axial play for the Standard 2500 ATG and no axial play for models with crank or cassette.
35. Secure the motor storage sheave assembly (48) with retaining ring (23). Use washer (44) and shim washers (45) as required. Test that sheave turns freely with 0.005" to 0.010" (0.13 to 0.25 mm) axial play.

36. Attach the spring motor to the tape storage sheave assembly and tighten screw (Fig. 3-1, item 7). Make sure the spring motor is not twisted out of alignment during screw tightening.
37. Refer to Chapter 3, With a Negator Spring Motor for winding the motor.
38. Open elbow sheave assemblies and inspect operation and condition. Replace cover gasket, defective sheaves and worn shafts as required. Lubricate the shaft and sheave with a light oil. To reinstall the tape or tape/cable, refer to Chapter 3, Installation — section , "Connecting the Tape to the Float" on page 45 through section , "Feeding the Tape to a Gauge Head Located at Grade Level" on page 49.
39. Proceed to section Counter Wheel Assembly on page 87.

Counter Wheel Assembly

If you remove the screws (43) and retainer from the counter wheel assembly (21) and the pinion gear (24) is disengaged, you must remove the dial and pinion gear in order to reset the counter drums and dial (7) to zero or to the calibrated liquid level.

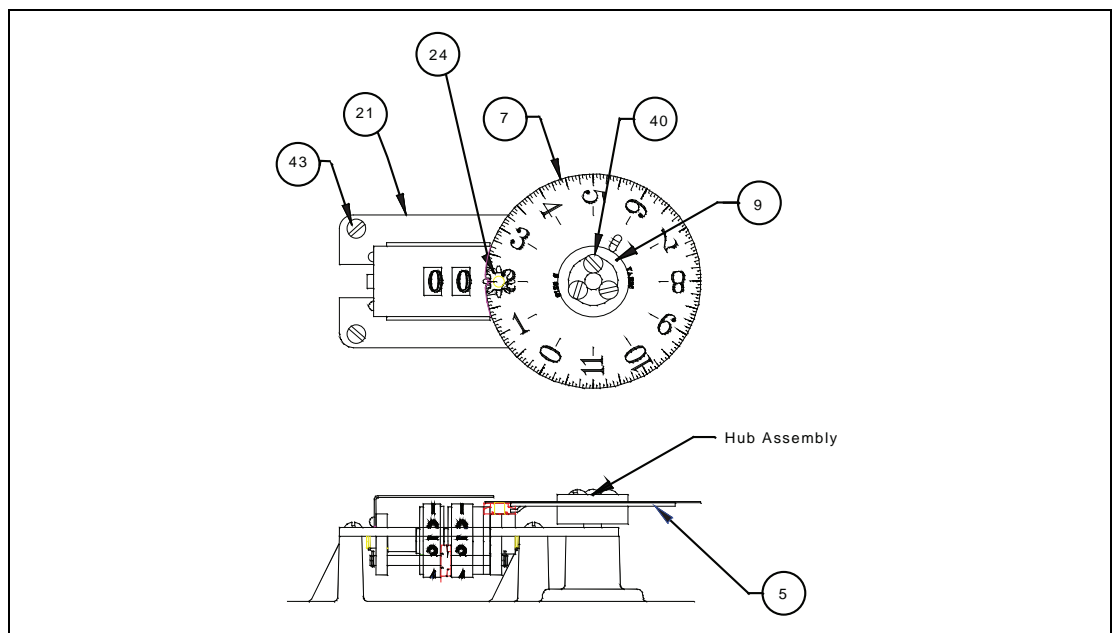

Figure 6-3: Counter Wheel Assembly

1. Place counter assembly (21) on supports and loosely install three mounting screws (43).
 - Do not tighten the screws.
2. With the pinion gear removed, rotate the counter assembly drums to display a whole number.

- The red-tipped pointer will be aligned with the center point between two teeth on the counter drum gear.
3. Examine the pinion gear. Note that from the top side, alternate teeth are high or low. From the bottom side, the 8 teeth are evenly aligned.
 4. With right thumb and finger, pick up the pinion gear by two of the high teeth and with the top side facing up.
 5. Install the pinion gear on the counter base shaft.
 - Set the gear with the 8-tooth side down against the counter base and so that the left-facing low tooth fits between two teeth of the counter drum gear.

Note The tops of the three teeth (1 pinion gear tooth and 2 counter drum gear teeth) should be aligned. If they are not, you may have set the pinion gear 1/2 notch out of position, and the counter display will also be off by that much.

6. Set the dial gear on the dial assembly hub without meshing the pinion gear teeth.
 - Set the dial gear with its tooth up, and turned away from the pinion gear.

Note To ensure the correct horizontal clearance, keep the dial gear tooth away from the pinion gear until step 9.

7. Ensure the correct vertical alignment between the dial gear and the pinion gear.
 - If the dial gear is below the top of the pinion gear, add shim washers ⁽⁴⁵⁾ under the counter shaft assembly ⁽¹¹⁾ as required. If the dial gear is higher than the pinion gear, remove shim washers from under the counter shaft assembly. If no shim washers are present, lightly tap the counter shaft assembly with a rubber mallet so that the dial gear and the pinion gear are level within 0.010" (0.25 mm).
8. Slip the dial under the red pointer and onto the hub.
9. Turn the dial until the tab from the dial gear slips into the slot in the plate.
10. Install the dial retainer ⁽⁹⁾, and secure it with the three screws ⁽⁴⁰⁾.
11. Rotate the dial assembly to ensure that it does not bind on the pointer or pinion gear and that it advances the counter drum one digit as it crosses the zero position.
12. If the dial assembly is too loose or too tight, adjust the positioning of the counter assembly ⁽²¹⁾.
 - The target clearance between pinion gear and dial gear is 0.010" (0.25 mm).
13. Tighten the counter assembly screws ⁽⁴³⁾.
14. Rotate the counter drums to set the level to the correct value.
15. To complete the assembly, refer to Chapter 3, Initial Lubrication.
 - That section gives instructions to reset and calibrate the counter.

Counter Bearing Adjustment Procedure

The counter bearing adjustment should be checked any time the dial is removed.

1. Remove the front cover.
2. Remove the graduated dial, retaining ring, and dial gear by removing one screw and loosening the other two.
3. Insert the Bearing Depth Gauge (02-0132252) as shown in Figure 44 below. Use the .214" (5.44 mm) end for black Vydyn dial gear gauges and the .250" (6.35 mm) end for sheet metal dial gear gauges.

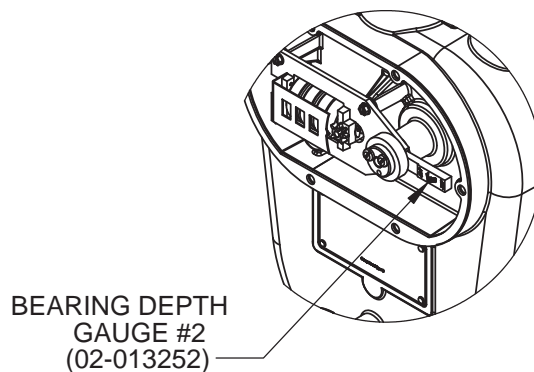
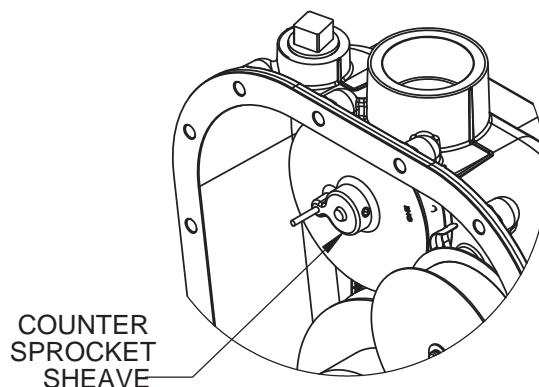
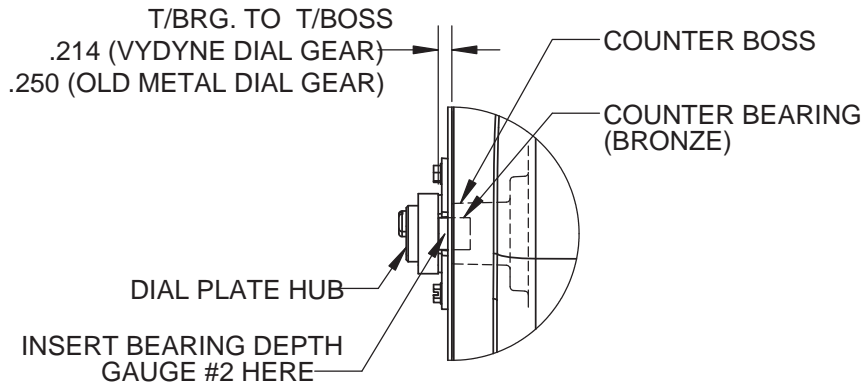

Figure 6-4: Bearing Depth Gauge

If the Bearing Depth Gauge does not fit between the counter boss and the dial plate hub, the bearing must be adjusted outward. Loosen the Tape Storage Sheave on the inside of the gauge and drive the bearing outward using a punch and hammer approximately 1/16" (1.6 mm) and recheck the depth. This adjustment requires a full disassembly of the gauge.



If there is play between the Bearing Depth Gauge, the counter boss, and the dial plate hub, tap the dial plate hub with a hammer with the Bearing Depth Gauge in place. When the dial plate hub is flush against the Bearing Depth Gauge, the counter bearing is adjusted correctly.



4. If there is slight axial play in the shaft, adjust the sprocket sheave on the inside of the gauge. This shaft must turn with minimal resistance.

7 Maintenance Routines

Varec recommends a regular schedule of maintenance for the 2500 Automatic Tank Gauge (ATG), outlined in the table below. Actual frequency of inspections and maintenance may vary depending on the specific environmental conditions and operation at your site—even from tank to tank. Study your installations, and plan a routine of inspection and maintenance that best suits your site’s individual needs. Regular maintenance lengthens the service life and assures more accurate gauge readings. Varec can provide spare parts, maintenance kits, and preventive maintenance advice, training, or warranties. Please consult your product Installation and Operations Manual or a representative for more information.

Warning! Hazardous environment! Observe appropriate safety precautions in flammable or hazardous liquid storage areas. Do not enter a tank that has contained hydrocarbons, vapors, or toxic materials, until a gas-free environment is certified. Carry breathing equipment when entering a tank where oxygen may be depleted with carbon dioxide, nitrogen or other gases.

Warning! Possible Electrostatic Discharge Hazard! Worker activity and worker clothing may accumulate electrostatic charges on the body of a worker. The mechanical connections between guide cables, float, tape, and gauge head provide a resistance to ground that is adequate for the safe electrical drain of electrostatic charges that may accumulate in the tank and the product.

Warning! Electrical and hazardous vapor hazards are inherent to the work described in this manual. Observe American Petroleum Institute (API) Recommended Practice 2003 or other appropriate industry or Military Standard.

The following table shows the suggested periodic maintenance and inspection routine for the 2500 ATG. Each element is described in the following paragraphs.

Maintenance Routines

| Routine | 90 Days | 6 Months | 1 Year - Inspect & Maintain | 5 Year - Inspect & Maintain | 10-Year API 653 Overhaul |
|------------------------------|---------|----------|---|-----------------------------|--------------------------|
| Operation check | X | X | X | | |
| Leak check | X | X | X | | |
| Sediment check | X | X | X | | |
| Deformation check | X | X | X | | |
| Calibration | | X | X | | |
| Float and guide cables check | | X | X | | |
| Lubricate | | | X | | |
| Oil-filled gauge check | | | X | | |
| Corrosion check | | | X | | |
| Basic Maintenance | | | As required - depending on service conditions. | | |
| Extended Maintenance | | | | | |
| Refurbish / Overhaul | | | | | Recommended |

Table 7-1: Suggested Periodic Maintenance Routines

Operation Check

Check the operation of the gauge by rotating the gauge check knob on the front of the gauge. The dial should show the movement of the float when the check knob is rotated.

Caution! Do not release the gauge check knob and allow the springs to return the mechanism. Over time, this will cause the springs to break and will jam the gauge.

Caution! Do not turn the gauge check knob on systems that have no float and that are directly connected to a floating roof.

Leak Check

Check the gauge head and conduit for signs of leaking, for example, look for cracks or corrosion that may cause the product to leak. If the gauge head is oil-filled, check for signs to assure that the gauge head is not leaking oil.

Sediment Check

Remove the NPT fitting on the bottom of the gauge head and check for sediment.

Deformation Check

Check the conduit for deformations that might inhibit the movement of the tape.

Calibration Check

Check the accuracy of the gauge against a hand dip measurement in the tank, and calibrate the gauge if necessary. Refer to “Calibrate the Counter” on page 60 for calibration instructions.

Float and Guide Wires Check

Using a man-way or inspection cover for access, check the guide wires and float. The guide wires should be tight and free of kinks to allow the float to run freely. Check the guide wires and float for sediment that might inhibit movement.

Lubrication and Oil Warnings

Caution! Do Not use any type of grease, WD-40, or lithium-based lubricant.

Warning! Before lubrication, ensure the chemical compatibility of the lubricant with the product in the tank.

Warning! Antifreeze must be compatible with aluminum.

Caution! These oils may not be compatible with edible oils and potable liquids. Use product-compatible substitutes for tanks holding products for human or animal consumption or products that may react chemically with the oil.

Caution! Gauges measuring caustic liquids require that the gauge head be oil filled.

Corrosion Check

Check for signs of corrosion. Interior corrosion of the pipe carrying the tape may become deposited in the mechanism and affect the accuracy.

Basic Maintenance

Basic maintenance should be conducted as required depending on the service conditions. The basic maintenance kit provides all the recommended parts that may need replacing during such a procedure. Follow the disassembly instructions in Chapter 6, Gauge Head Disassembly and Re-assembly when replacing any parts on the gauge head.

Extended Maintenance

Extended maintenance should be conducted as required depending on the service conditions. The extended maintenance kit provides all the recommended parts that may need to be replaced during such a procedure. Follow the disassembly instructions in Chapter 6 on page 81 when replacing any parts on the gauge head.

Overhaul / Maintenance

A complete gauge head overhaul or refurbish should be conducted as part of an API 653 tank overhaul. The overhaul maintenance kit provides all the recommended parts that may need to be replaced during such a procedure. Follow the disassembly instructions in Chapter 6, Gauge Head Disassembly and Re-assembly when replacing any parts on the gauge head.

General Inspection

It is recommended that you schedule the first inspection after the unit has been in service for the end of the first thirty-day period. Subsequent inspections should be made every 90 days. The user may adjust the schedule for his own convenience and safety, depending upon the product.

Varec maintenance service contracts are available. Please consult a sales or service representative for further details.

8 Spare Parts and Maintenance Kits

Varec can supply individual spare parts for the 2500 ATG, maintenance kits, and installation accessories. The following kits are specifically designed to assist with a regular schedule of maintenance and to improve the quality and performance of your 2500 ATG. This chapter details the contents of each kit and provides an illustration to assist in locating the part within the assembly. Refer to the Maintenance Procedures - Disassembly and Assembly, before performing any maintenance on the gauge head.

| Part # | Description | See page: |
|--------------|--------------------------------------|-----------|
| 13-08766 | Basic Maintenance Kit - Imperial | page 107 |
| 13-08767 | Basic Maintenance Kit - Metric | |
| 13-08768 | Extended Maintenance Kit - Imperial | page 109 |
| 13-08769 | Extended Maintenance Kit - Metric | |
| 13-08770 | Overhaul/Refurbishing Kit - Imperial | page 112 |
| 13-08771 | Overhaul/Refurbishing Kit - Metric | |
| 13-09794-00 | Shoulder Bushing Retrofit Kit | page 116 |
| 13-10652 | Negator Cassette and Kit | page 119 |
| 13-10974-006 | Float Grounding Kit | page 120 |

Table 8-1: Maintenance Kits List

Gauge Head Spare Parts

| Item | Part | Description |
|------|---------------|--|
| 1 | B4396-046 | Back Cover Gasket (Cast gauge head) - A (Prior to 1983) |
| | 02-04490-046 | Back Cover Gasket - B (1983 - 2012) |
| | 02-013127-046 | Back Cover Gasket - C (2013 and Later) |
| 2 | B5059-046 | Back Cover Cap Gasket |
| 3 | B5060-001 | Back Cover Cap |
| 4 | B7415-093 | Teflon Washer |
| 5 | B8235-040 | Imperial Dial Gear |
| | B8327-040 | Metric Dial Gear |
| 6 | 02-013187-046 | Counter Cover Gasket |
| 7 | B8218-001 | Imperial Dial (Fractional or Decimal) - innage |
| | B8325-001 | Metric Dial - innage and outage |
| | B9616-001 | Imperial Dial - (Fractional or Decimal) - outage |
| 8 | BA7761 | Tape Storage Sheave Assembly (Includes item 57) |
| | BA9796 | Crank Tape Storage Sheave |
| | 06-10364 | Tape Storage Sheave Assembly - Cassette |
| 9 | B8234-001 | Dial Retainer |
| 10 | B7693-005 | Shaft (2) - Gauge Head Type B |
| | BA7763 | Shaft Support Assembly - Gauge Head Type C and Cast Iron (2) |
| 11 | BA17597 | Counter Shaft Assembly |
| 12 | B10221-093 | Seal |
| 13 | P34-4 | Knob |
| 14 | BA14055 | Gauge Check Assembly (includes items 61 & 62) |
| 15 | B7796-005 | Gauge Check Spring |
| 16 | B6547-005 | Tape Keeper Post |
| 17 | 02-04488 | Back Cover: <ul style="list-style-type: none"> If 16 holes - Type B If 17 holes - Type C |
| 18 | 06-08558 | Imperial Sprocket Sheave Assembly (includes item 28) |
| | 06-08559 | Metric Sprocket Sheave Assembly (includes item 28) |
| 19 | DA4044 | Counter Cover Assembly (includes items 53 & 54) |
| 21 | BM18849-100 | Imperial Counter Assembly-Innage |
| | BM18850-100 | Metric Counter Assembly-Innage |
| | BM19954-100 | Imperial Counter Assembly-outage |
| | BM19955-100 | Metric Counter Assembly-outage |

| Item | Part | Description |
|------|--------------|--|
| 22 | P14-146 | O Ring |
| 23 | P10-2 | Retaining Ring (2) |
| 24 | P25-16 | Pinion Gear |
| 25 | B7300-005 | Tape Keeper Spring |
| 26 | P14-23 | O Ring Seal |
| 27 | P31-669 | Binding Head Mach. Screw |
| 28 | P031-04-1697 | Set Screw (for counter sprocket) |
| 29 | P10-29 | Grip Ring |
| 31 | P13-20 | Bushing (2) |
| 33 | 02-08543 | Washer |
| 34 | P030-04-822 | 1½" NPT Plug |
| 35 | P30-237 | ½" NPT Plug (Type B- Top) |
| | P030-04-838 | ¾" NPT Plug (Type C) |
| 36 | P031-32-1661 | Washer |
| 37 | B4847-005 | Washer |
| 38 | P031-05-1721 | Back Cover Bolts |
| 39 | P031-05-1871 | Counter Cover Bolts |
| 40 | P031-01-1719 | Dial Retaining Screw (Brass for Counter) |
| 41 | P31-247 | Hex Jam Nut (for Back Cap) |
| 42 | P31-612 | Set Screw |
| 43 | P031-08-1720 | Counter Base Screws |
| 44 | P31-1 | Washer (2) |
| 45 | P31-13 | Shim Washer |
| 46 | P030-04-802 | 3/8" NPT Plug (Type B bottom drain); N/A (Type C) |
| 47 | P031-05-1601 | Hex Head Cap Screw (for Back Cap) |
| 48 | P1-5 | Negator Motor Only |
| | BA7762 | Negator Motor Sheave Assembly (includes items 55x2 & 56) |
| | P1-26 | Negator Motor Only (for extended range) |
| | BA17087 | Negator Motor Sheave Assembly (for extended range) |
| 49 | P031-11-1887 | Hex Socket Cap Screw |
| 50 | 06-10368 | Negator Cassette |
| 52 | 06-10490 | Crank Handle Assy - Cassette ¹ |
| | BM3784 | Crank Handle, Steel - Tape storage sheaves w/ PTFE bushings ² |
| 53 | P30-236 | Top Counter ¼" NPT Plug |
| 54 | B12759-003 | Bottom Counter ¼" NPT Drain Plug |
| 55 | 02-09598 | Bushing, shoulder (PTFE) (Type B: Qty = 4; Type C: Qty = 2) |

| Item | Part | Description |
|-------------|--------------|--------------------------------------|
| 56 | B14872-101 | Motor Top Plate (standard range) |
| | B17086-101 | Motor Top Plate (for extended range) |
| 57 | P31-671 | Screw (motor output) |
| 61 | B7790-005 | Check Pawl |
| 62 | B7795-005 | Hair Pin Spring |
| 76 | B8774-005 | Pinion - Crank |
| 77 | B9304-005 | Pawl Spacer - Crank |
| 78 | B9750-005 | Spring Support Guide - Crank |
| 79 | B9302-001 | Crank Direction Label |
| 80 | B9797-005 | Crank Ratchet Spring |
| 81 | B10938-011 | Ratchet Gear - Crank |
| 82 | B10939-011 | Pawl, Ratchet - Crank |
| 83 | D6360-011 | Crank Handle |
| 84 | B10147-005 | Crank Shaft |
| 85 | P1-19 | Spring Crank Shaft |
| 86 | B6665-011 | Crank Handle Knob |
| 87 | 02-05824-011 | Crank Pawl Housing |
| 88 | P20-68 | Spring Pin, for Crank |
| 89 | P20-14 | Roll Pin, for Crank |
| 90 | P031-03-1757 | Screws for Crank Ratchet Gear |
| 91 | P31-351 | Screws for Crank Ratchet Cover |
| 92 | P31-630 | Screws for Crank Ratchet |
| 93 | P31-347 | Hex Nut for Crank Knob |
| 95 | P031-11-1723 | Bolt for Crank Knob |
| 100 | 02-013223 | PTFE Shim for checker |

Table 8-2: 2500 ATG Gauge Head Spare Parts List

Cartridge Crank Handles as provisioned as follows:

¹ Handle 06-10490 fits all gauges in which the tape storage sheave has ball bearings & iron sheaves 2017 and later

² Handle BM3784 was made of Type B gauges prior to 2008 & Cast Iron gauges prior to 2017

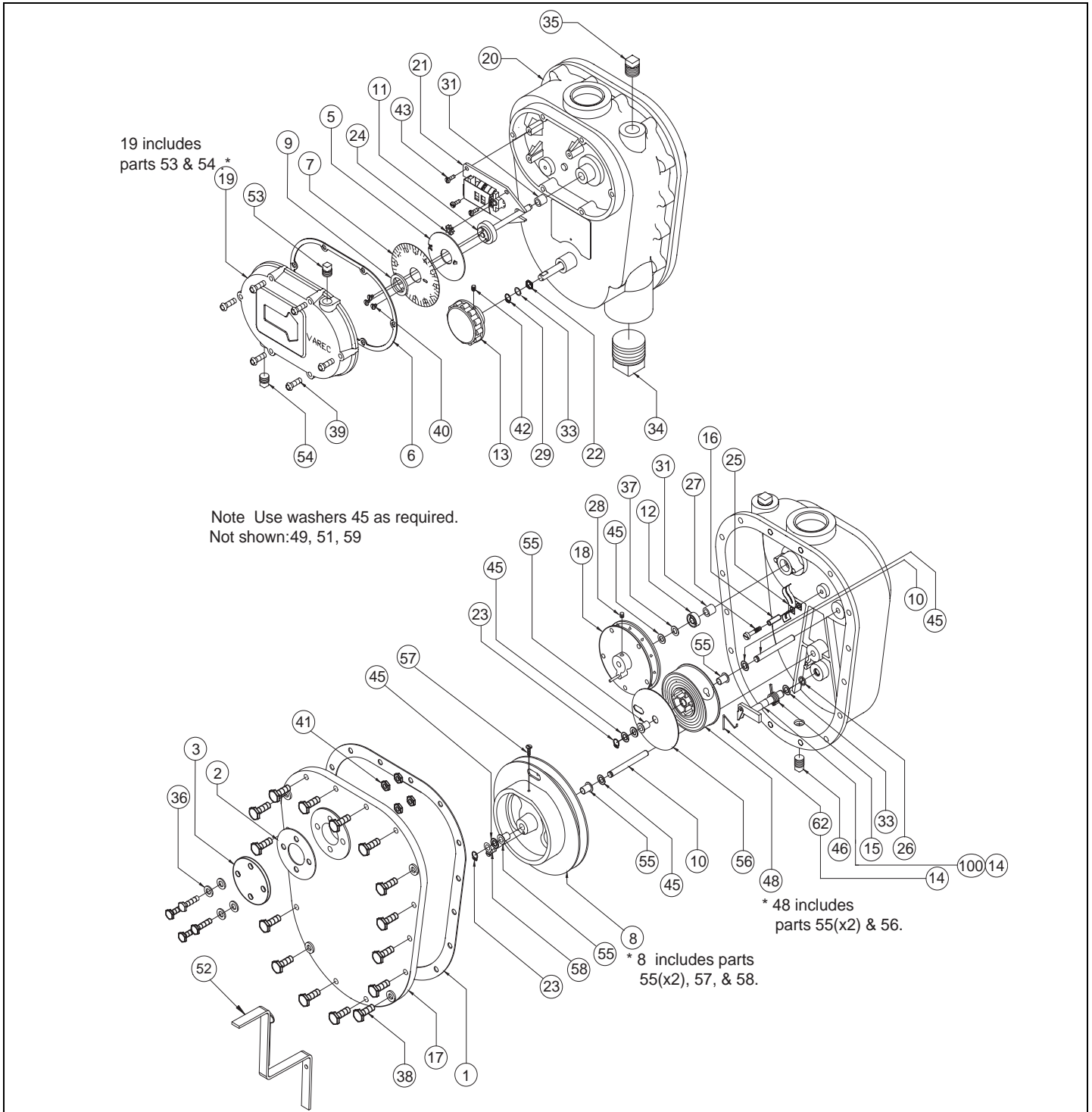

Figure 8-1: 2500 ATG Gauge Head (Type B) with Negator Motor Spare Parts Diagram

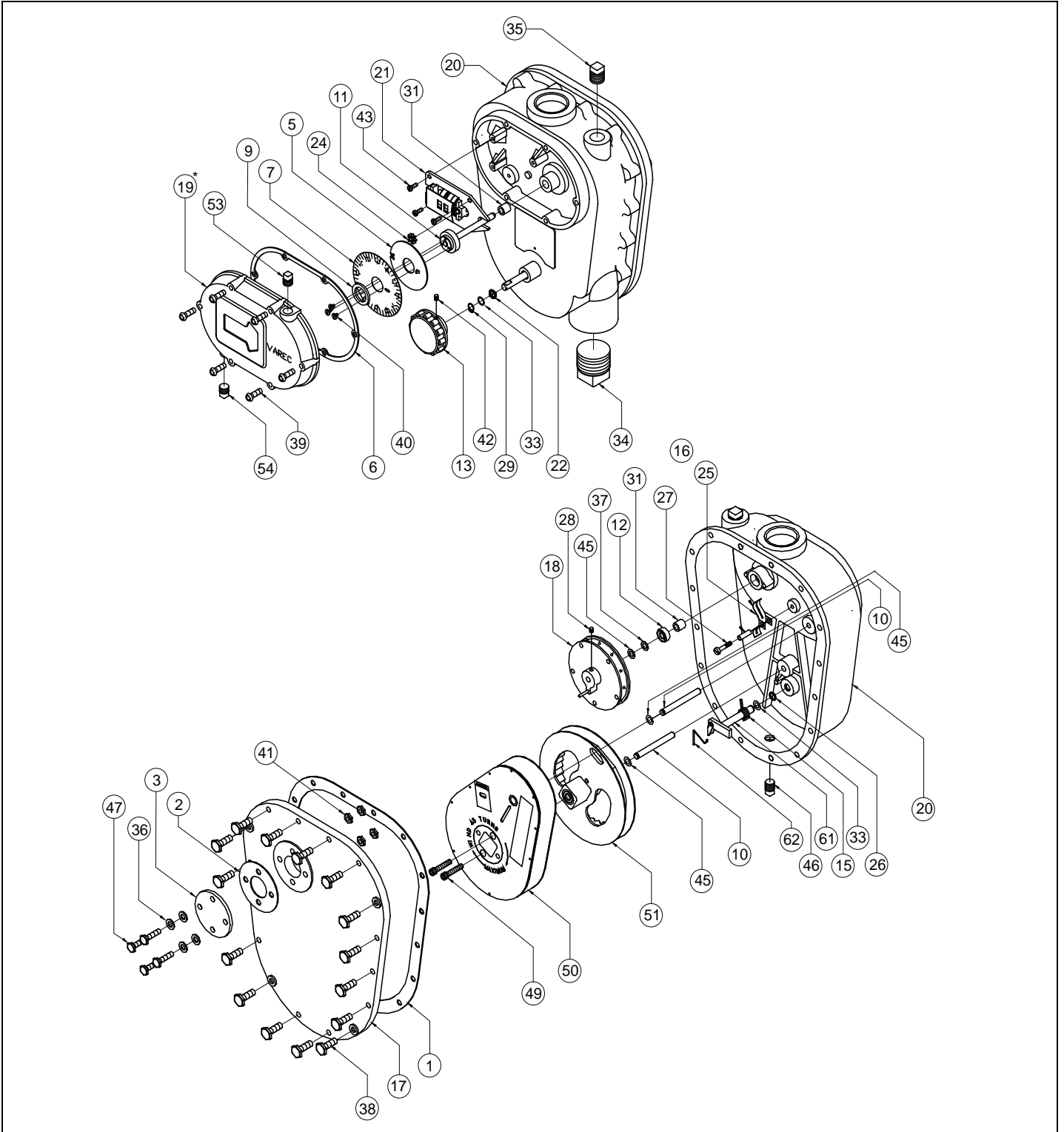

Figure 8-2: 2500 ATG Gauge Head (Type B) with Negator Cassette Spare Parts Diagram

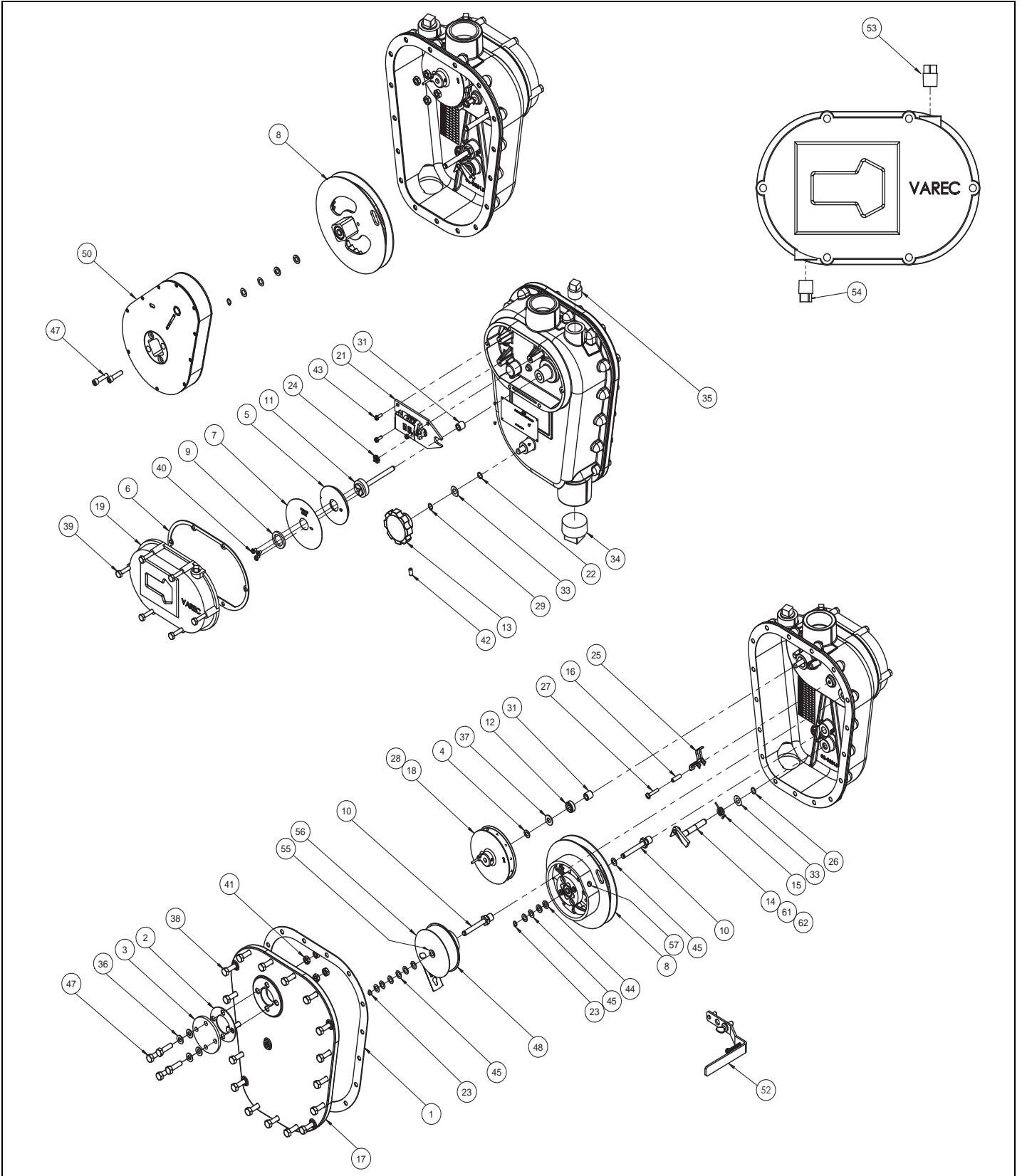

Figure 8-3: 2500 ATG Gauge Head (Type C) with Negator Motor and Negator Cassette Spare Parts Diagram

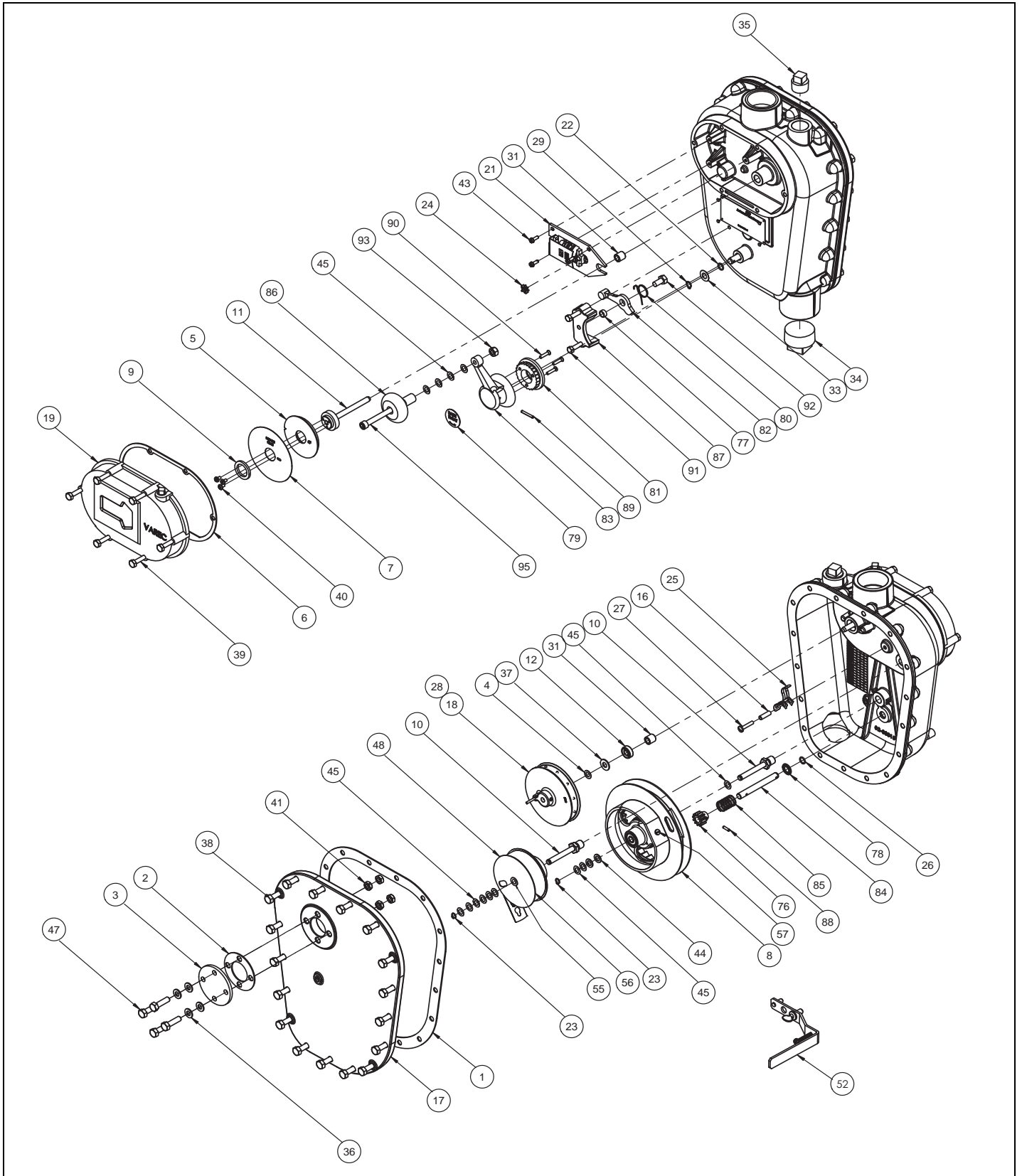

Figure 8-4: 2500 ATG Gauge Head with Hand Crank

2500 Cast Iron Gaugehead Spare Parts

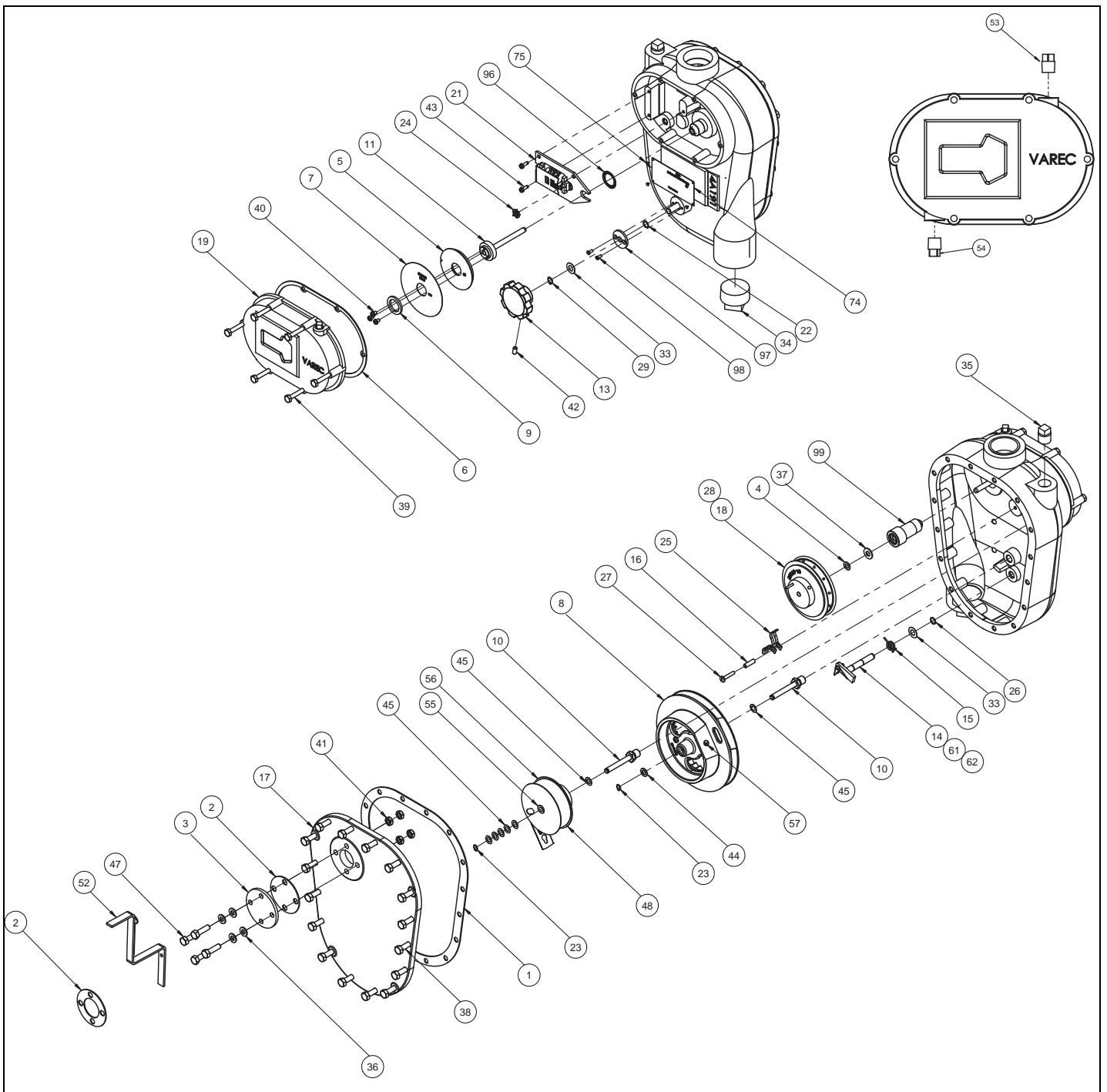

Figure 8-5: 2500 Cast Iron Gaugehead

| Item | Part | Description |
|------|-----------|---|
| 01 | B4396-046 | Back Cover Gasket (Type A Gaugeheads prior to 1983, and Low Pressure Iron Gaugeheads) |

Spare Parts and Maintenance Kits

| Item | Part | Description |
|------|---------------|---|
| 02 | B5059-046 | Back Cover Cap Gasket (For a transmitter) |
| | B5059-146 | Back Cover Cap Gasket - No center hole (if no transmitter) |
| 03ci | B5060-001-7 | Back Cover Cap, Painted (Cast Iron Gaugehead) |
| 04 | B7415-093 | Teflon Washer (Not shown - used on older Gaugeheads) |
| 05 | B8235-040 | English Dial Gear |
| | B8327-040 | Metric Dial Gear |
| 06 | 02-013187-046 | Counter Cover Gasket |
| 07 | B8218-001 | English Dial Plate (Fractional or Decimal) |
| | B8325-001 | Metric Dial Plate (30 cm Graduations) Innage/Outage |
| 08ci | BB7761 | Tape Storage Sheave Assembly (Includes item 58) (Cast Iron Gaugehead) |
| 09 | B8234-001 | Dial Retainer |
| 10 | BA7763 | Shaft Support Assy (2) (Type C & Cast Iron Gaugeheads) |
| 11 | BA17597 | Counter Shaft/Hub Assembly |
| 13 | P34-4 | Knob, Phenolic, Black |
| 14 | BA14055 | Gauge Check Assembly (includes items 61 & 62) |
| 15 | B7796-005 | Gauge Check Spring - 304 SS |
| 16 | B6547-005 | Tape Keeper Post |
| 17 | D1895-002 | Back Cover - Cast Iron (16 bolt holes) |
| 18 | DB3197 | Cast Iron Sprocket Sheave Assy - English (Cast Iron Gaugeheads) (Includes 2 # 28) |
| | DB3930 | Cast Iron Sprocket Sheave Assy - Metric (Cast Iron Gaugeheads) (Includes 2 # 28) |
| 19 | DA4044-7 | Counter Cover Assembly - Painted (includes items 53 & 54) |
| 21 | BM18849-100 | English Counter Assembly |
| | BM18850-100 | Metric Counter Assembly |
| 22 | P14-146 | O-Ring Seal-Viton |
| 23 | P10-2 | Retaining Ring, ((2) std motors, (1) cassettes) |
| 24 | P25-16 | Pinion Gear |
| 25 | B7300-005 | Tape Keeper Spring |
| 26 | P14-23 | O Ring Seal, Teflon |
| 27 | P31-669 | Screw (for tape keeper) |
| 28 | P31-1467 | (2) Set Screw (for Counter Sprocket) |
| 29 | P10-29 | Grip Ring 3/8" |
| 33 | 02-08543 | Washer, shim |
| 34 | P030-04-822 | 1-1/2 NPT Plug |
| 35 | P30-237 | 1/2 NPT Top Plug (Type B Gaugeheads & iron) |

| Item | Part | Description |
|------|--------------|--|
| 36 | P031-32-1661 | Washer, Fiber |
| 37 | B4847-005 | Washer, (Inside at counter) |
| 38 | P031-05-1721 | Back Cover Bolts |
| 39 | P031-05-1871 | Hex Head Cap Screw (Counter cover) |
| 40 | P031-01-1719 | Binding Head Mach. Screw (Brass for counter) |
| 41 | P31-247 | Hex Jam Nut (For back cap) |
| 42 | P31-612 | Set Screw, (For check knob) |
| 43 | P031-08-1720 | Screw (For counter base) |
| 44 | P31-1 | Washer |
| 45 | P31-13 | Shim washer |
| 47 | P031-05-1601 | Hex Head Cap Screw (For back cap) |
| 48 | BC7762 | Negator Motor Sheave Assembly (Cast Iron Gaugeheads, includes items 55x2 & 56) |
| 52 | BM3784 | Crank Handle, Steel - Tape storage sheaves w/ PTFE bushings |
| 53 | P30-236 | Top Counter 1/4 NPT Plug |
| 54 | B12759-003 | Bottom Counter 1/4 NPT Drain Plug |
| 55 | 02-09598 | Bushing, shoulder (PTFE) |
| 56 | B14872-105 | Motor Top Plate, For Iron Gauge |
| 57 | P31-671 | Screw (Motor, output) |
| 61 | B7790-005 | Check Pawl |
| 62 | B7795-005 | Hair Pin Spring |
| 96 | P10-54 | Retaining Ring for Counter Gland (Cast Iron Gaugeheads) |
| 97 | B14057-001-7 | Gauge Check Seal Plate (Cast Iron Gaugeheads) |
| 98 | P31-1113 | Seal Plate Screws (Cast Iron Gaugeheads) |
| 99 | BE18440 | Counter Gland Assy (Cast Iron Gaugeheads) |

Basic Maintenance Kit

The Basic Maintenance Kit provides all the parts required for basic maintenance on the 2500 ATG. Depending on your selection, you will receive the metric or imperial parts required.

Spare Parts and Maintenance Kits

| Part No. | | Description | |
|----------|---------------|---|-----------------------|
| 13-08766 | | Basic Maintenance Kit - Imperial | |
| 13-08767 | | Basic Maintenance Kit - Metric | |
| Item | Part No. | Description | Quantity in Kits |
| 1 | B4396-046 | Back Cover Gasket 2500A (Prior to 1983) | 1 |
| | 02-04490-046 | Back Cover Gasket 2500B (1983 - 2012) | 1 |
| | 02-013127-046 | Back Cover Gasket 2500C (2013 and later) | 1 |
| 4 | B7415-093 | Teflon Washer | 1 |
| 5 | B8235-040 | Imperial Dial Gear | 1 (Imperial kit only) |
| 5m | B8327-040 | Metric Dial Gear | 1 (Metric kit only) |
| 6 | 02-013187-046 | Counter Cover Gasket | 1 |
| 7 | B8218-001 | Imperial Dial (Fractional or Decimal) | 1 (Imperial kit only) |
| 7m | B8325-001 | Metric Dial | 1 (Metric kit only) |
| 15 | B7796-005 | Gauge Check Spring | 1 |
| 16 | B6547-005 | Tape Keeper Post | 1 |
| 21 | BM18849-100 | Imperial Counter Assembly | 1 (Imperial kit only) |
| 21m | BM18850-100 | Metric Counter Assembly | 1 (Metric kit only) |
| 23 | P10-2 | Retaining Ring | 4 |
| 24 | P25-16 | Pinion Gear | 1 |
| 25 | B7300-005 | Tape Keeper Spring | 1 |
| 27 | P31-669 | Binding Head Mach. Screw | 1 |
| 40 | P031-01-1719 | Binding Head Mach. Screw | 3 |
| 43 | P031-08-1720 | Counter Screw | 3 |
| 44 | P31-1 | Washer | 6 |
| 45 | P31-13 | Shim Washer | 18 |
| 55 | 02-09598 | Shoulder Bushing | 4 |
| 56 | B14872-101 | Motor Top Plate | 1 |
| 62 | B7795-005 | Hair Pin Spring | 1 |
| 72 | P031-29-1883 | Slotted Shim (not shown) | 1 |

Table 8-3: Basic Maintenance Kits and Parts Numbers List

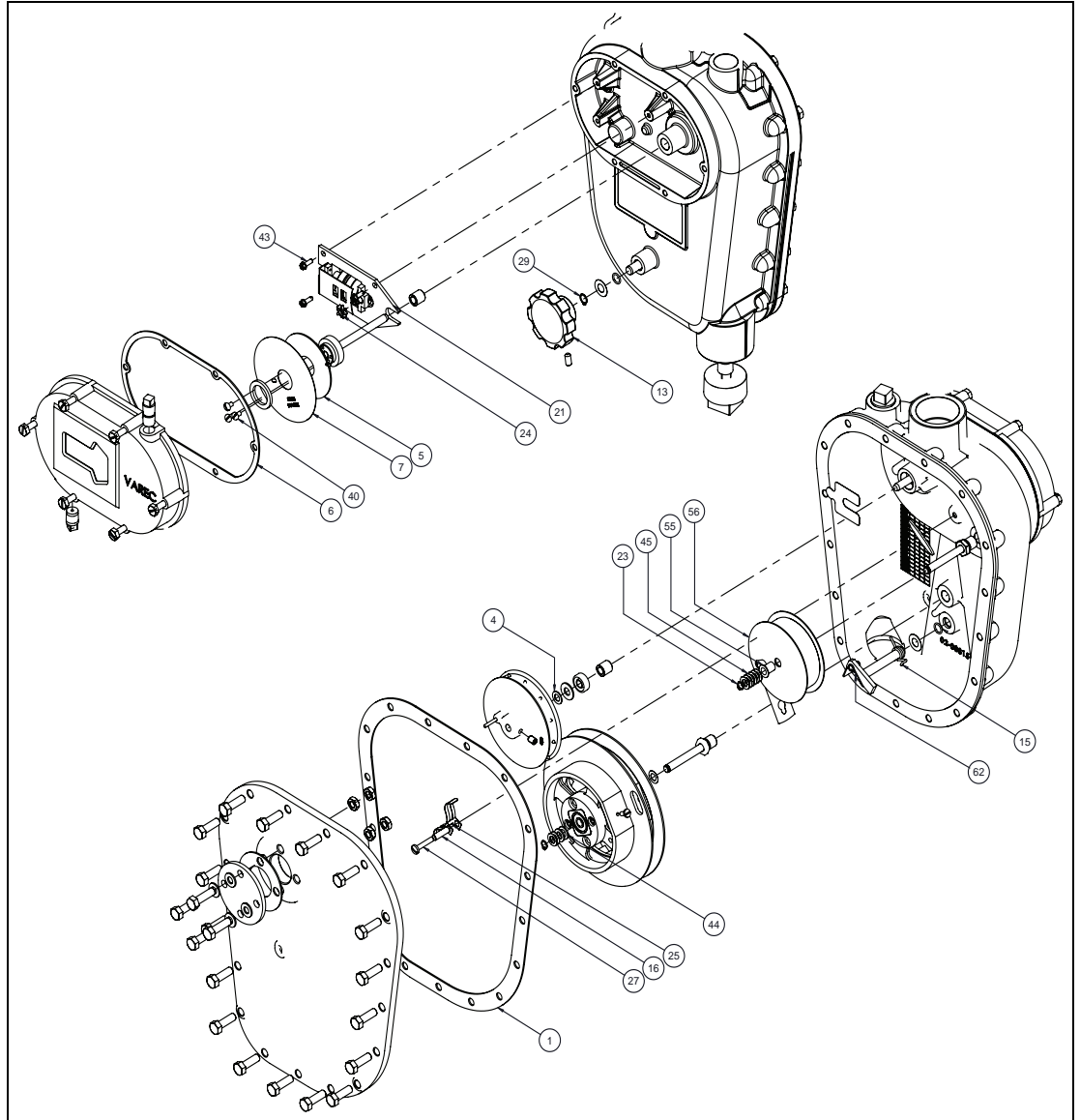

Figure 8-6: 2500 ATG (Type C Gauge Head Shown) Basic Maintenance Kit Parts Diagram

Extended Maintenance Kit

The Extended Maintenance Kit provides all the parts required for extended maintenance on the 2500 ATG Gauge Head. Depending on your selection, you will receive the metric or imperial parts required, listed in Table .

Spare Parts and Maintenance Kits

| Part No. | Description | |
|----------|---|--|
| 13-08768 | 1 - Extended Maintenance Kit - Imperial | |
| 13-08769 | 2 - Extended Maintenance Kit - Metric | |

| Item | Part No. | Description | Quantity in Kits |
|------|---------------|---|-----------------------|
| 1 | B4396-046 | Back Cover Gasket 2500A (Prior to 1983) | 1 |
| | 02-04490-046 | Back Cover Gasket 2500B (1983 - 2012) | 1 |
| | 02-013127-046 | Back Cover Gasket 2500C (2013 and later) | 1 |
| 4 | B7415-093 | Teflon Washer | 1 |
| 5 | B8235-040 | Imperial Dial Gear | 1 (Imperial kit only) |
| 5m | B8327-040 | Metric Dial Gear | 1 (Metric kit only) |
| 6 | 02-013187-046 | Counter Cover Gasket | 1 |
| 7 | B8218-001 | Imperial Dial (Fractional or Decimal) | 1 (Imperial kit only) |
| 7m | B8325-001 | Metric Dial | 1 (Metric kit only) |
| 9 | B8234-001 | Dial Retainer | 1 |
| 12 | B10221-093 | Seal | 1 |
| 14 | BA14055 | Gauge Check Assembly | 1 |
| 15 | B7796-005 | Gauge Check Spring | 1 |
| 16 | B6547-005 | Tape Keeper Post | 1 |
| 21 | BM18849-100 | Imperial Counter Assembly | 1 (Imperial kit only) |
| 21m | BM18850-100 | Metric Counter Assembly | 1 (Metric kit only) |
| 22 | P14-146 | O Ring | 1 |
| 23 | P10-2 | Retaining ring, 5/16 SS | 4 |
| 24 | P25-16 | Pinion Gear | 1 |
| 25 | B7300-005 | Tape Keeper Spring | 1 |
| 26 | P14-23 | O Ring Seal | 1 |
| 27 | P31-669 | Binding Head Mach. Screw | 1 |
| 29 | P10-29 | Grip Ring | 1 |
| 31 | P13-20 | Bushing | 1 |
| 33 | 02-08543 | Washer | 2 |
| 37 | B4847-005 | Washer | 1 |
| 39 | P031-05-1871 | Hex Head Cap Screw | 6 |
| 40 | P031-01-1719 | Binding Head Mach. Screw | 3 |
| 42 | P31-612 | Hex Socket Set Screw, Cup Pt. | 1 |
| 43 | P031-08-1720 | Counter Screw | 3 |
| 44 | P31-1 | Washer | 1 |

| Item | Part No. | Description | Quantity in Kits |
|------|--------------|---|------------------|
| 45 | P31-13 | Shim Washer | 18 |
| 48 | BA7762 | Negator Motor Assy (includes items 55x2 & 56) | 1 |
| 52 | 06-10490 | Crank Handle Assy - Cassette | 1 |
| 55 | 02-09598 | Shoulder Bushing | 2 |
| 57 | P31-671 | Screw | 1 |
| 72 | P031-29-1883 | Slotted Shim | 1 |
| 73 | 02-013252 | Counter Bearing Depth Gauge (not shown) | 1 |
| AA | BM5478-600 | Snap Type Connector Kit | 1 |
| BB | A371-046 | Cover Gasket (sheave elbow) | 2 |
| JJ | P31-150 | Hex Head Cap Screw | 2 |
| KK | A370-006 | Elbow Yoke | 2 |

Table 8-4: Extended Maintenance Kit Parts List

Additional items

When performing extended maintenance, Varec also recommends replacing the tape or the tape-and-cable combination as shown in the following table.

| Item | Part No. | Description |
|------|------------|---|
| EE | B7650-606 | Tape - Imperial (Length 136'), (316 SS) for a tank 60 ft high |
| | B7650-306 | Tape - Imperial (Length 80'), (316 SS) for a tank 32 ft high |
| | B9736-606 | Tape - Metric (Length 41.25 m), (316 SS) for a tank 18.29 m high |
| | B9736-306 | Tape - Metric (Length 24.38 m), (316 SS) for a tank 9.75 m high |
| FF | B7678-606 | Tape and Cable (\emptyset 3/32") Combination - Imperial (Length 133') for a tank 60 ft high |
| | B7678-306 | Tape and Cable (\emptyset 3/32") Combination - Imperial (Length 73') for a tank 30 ft high |
| | B13982-606 | Tape and Cable (\emptyset 3/32") Combination - Metric (length 44.5 m) for a tank 18 m high |
| | B7678-106 | Tape and Cable (\emptyset 3/32") Combination - Imperial (Length 73') for a tank 30 ft high |
| | B13982-306 | Tape and Cable (\emptyset 3/32") Combination - Metric (Length 22.2 m) for a tank 9 m high |

Table 8-5: Additional Items Recommended for Extended Maintenance List

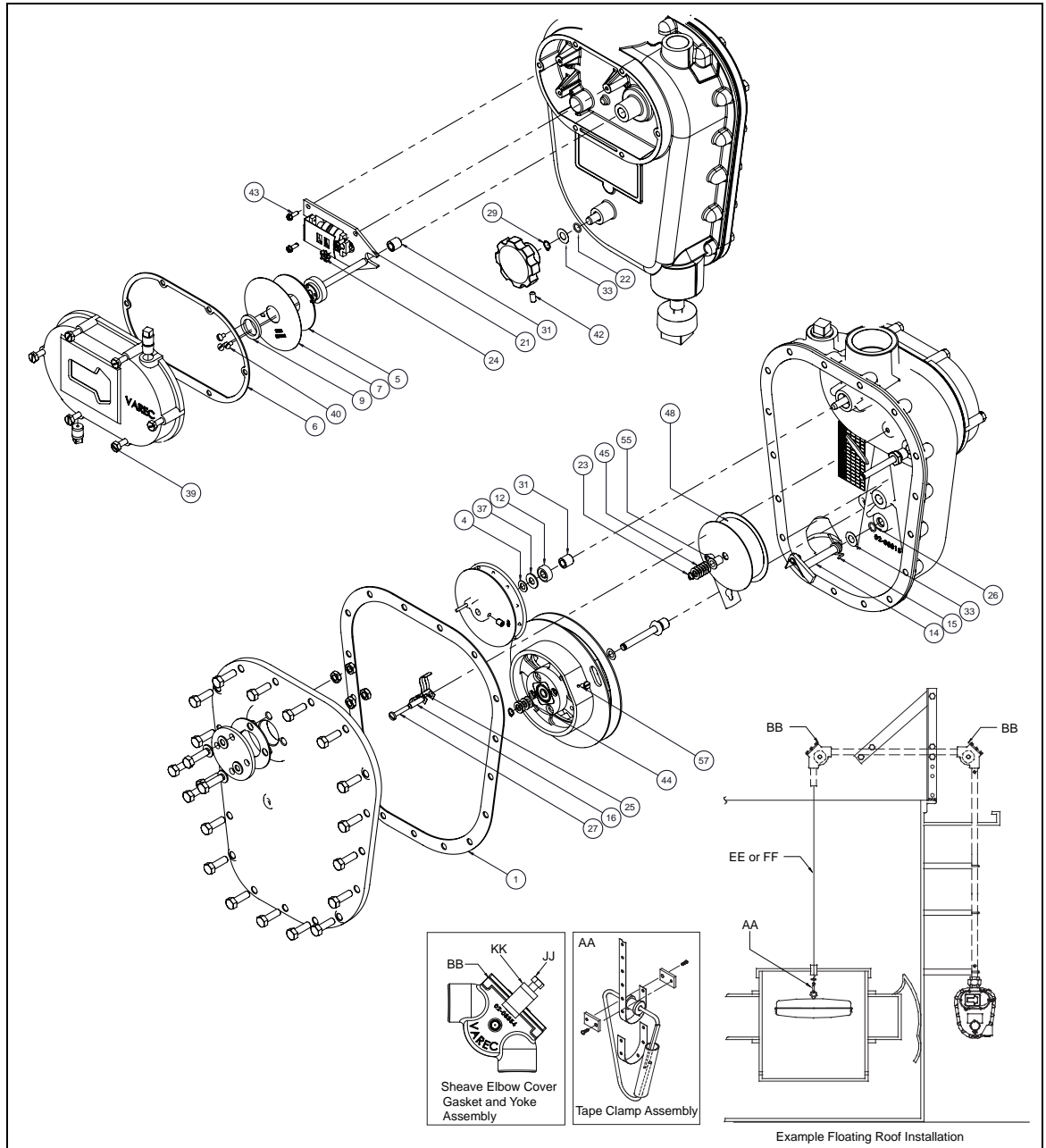

Figure 8-7: 2500 ATG (Type C Gauge Head Shown) Extended Maintenance Kit Parts Diagram

Overhaul/Refurbishing Kit

The Refurbish/Overhaul Kit provides all the parts required for overhaul maintenance on the 2500 ATG. Depending on your selection, you will receive the metric or imperial parts required, listed in Table 8-8

| Part No. | Description | |
|----------|--|--|
| 13-08770 | Overhaul/Refurbishing Maintenance Kit - Imperial | |
| 13-08771 | Overhaul/Refurbishing Kit - Metric | |

| Item | Part No. | Description | Quantity in Kits |
|------|---------------|--|-----------------------|
| 1 | B4396-046 | Back Cover Gasket 2500A (Prior to 1983) | 1 |
| | 02-04490-046 | Back Cover Gasket 2500B (1983 - 2012) | 1 |
| | 02-013127-046 | Back Cover Gasket 2500C (2013 and later) | 1 |
| 4 | B7415-093 | Teflon Washer | 1 |
| 5 | B8235-040 | Imperial Dial Gear | 1 (Imperial kit only) |
| 5m | B8327-040 | Metric Dial Gear | 1 (Metric kit only) |
| 6 | 02-13187-046 | Counter Cover Gasket | 1 |
| 7 | B8218-001 | Imperial Dial (Fractional or Decimal) | 1 (Imperial kit only) |
| 7m | B8325-001 | Metric Dial | 1 (Metric kit only) |
| 8 | BA7761 | Tape Storage Sheave Assembly (Includes item 57) | |
| 9 | B8234-001 | Dial Retainer | 1 |
| 12 | B10221-093 | Seal | 1 |
| 14 | BA14055 | Gauge Check Assembly | 1 |
| 15 | B7796-005 | Gauge Check Spring | 1 |
| 16 | B6547-005 | Tape Keeper Post | 1 |
| 21 | BM18849-100 | Imperial Counter Assembly | 1 (Imperial kit only) |
| 21m | BM18850-100 | Metric Counter Assembly | 1 (Metric kit only) |
| 22 | P14-146 | O Ring | 1 |
| 23 | P10-2 | Retaining Ring | 4 |
| 24 | P25-16 | Pinion Gear | 1 |
| 25 | B7300-005 | Tape Keeper Spring | 1 |
| 26 | P14-23 | O Ring Seal | 1 |
| 27 | P31-669 | Binding Head Mach. Screw | 1 |
| 29 | P10-29 | Grip ring | 1 |
| 31 | P13-20 | Bushing | 1 |
| 33 | 02-08543 | Washer | 2 |
| 37 | B4847-005 | Washer | 1 |
| 38 | P031-05-1721 | Hex Head Cap Screw | 17 |
| 39 | P031-05-1871 | Hex Head Cap Screw | 6 |
| 40 | P031-01-1719 | Binding Head Mach. Screw | 3 |

Spare Parts and Maintenance Kits

| Item | Part No. | Description | Quantity in Kits |
|------|--------------|--|------------------|
| 42 | P31-612 | Hex socket set screw, Cup Pt. | 1 |
| 43 | P031-08-1720 | Counter Screw | 3 |
| 44 | P31-1 | Washer | 6 |
| 45 | P31-13 | Shim Washer | 18 |
| 48 | BA7762 | Negator Motor Assembly (includes items 55x2 & 56) | 1 |
| 52 | 06-10490 | Crank Handle Assy - Cassette | 1 |
| 55 | 02-09598 | Shoulder Bushing | 2 |
| 56 | B14872-101 | Motor Top Plate | 1 |
| 57 | P31-671 | Screw | 1 |
| 58 | P31-692 | Screw | 1 |
| 72 | P013-29-1883 | Slotted Shim | 1 |
| 73 | 02-013252 | Counter Bearing Depth Gauge (not shown) | 1 |
| AA | BM5478-600 | Snap Type Connector Kit | 1 |
| BB | A371-046 | Cover Gasket (sheave elbow) | 2 |
| JJ | P31-150 | Elbow Bolt | 2 |
| KK | A370-006 | Elbow Yoke | 2 |
| | 13-10974-006 | Float Grounding Cable (Not Shown) | 1 |

Figure 8-8: Overhaul/Refurbish Maintenance Kit Part Numbers List

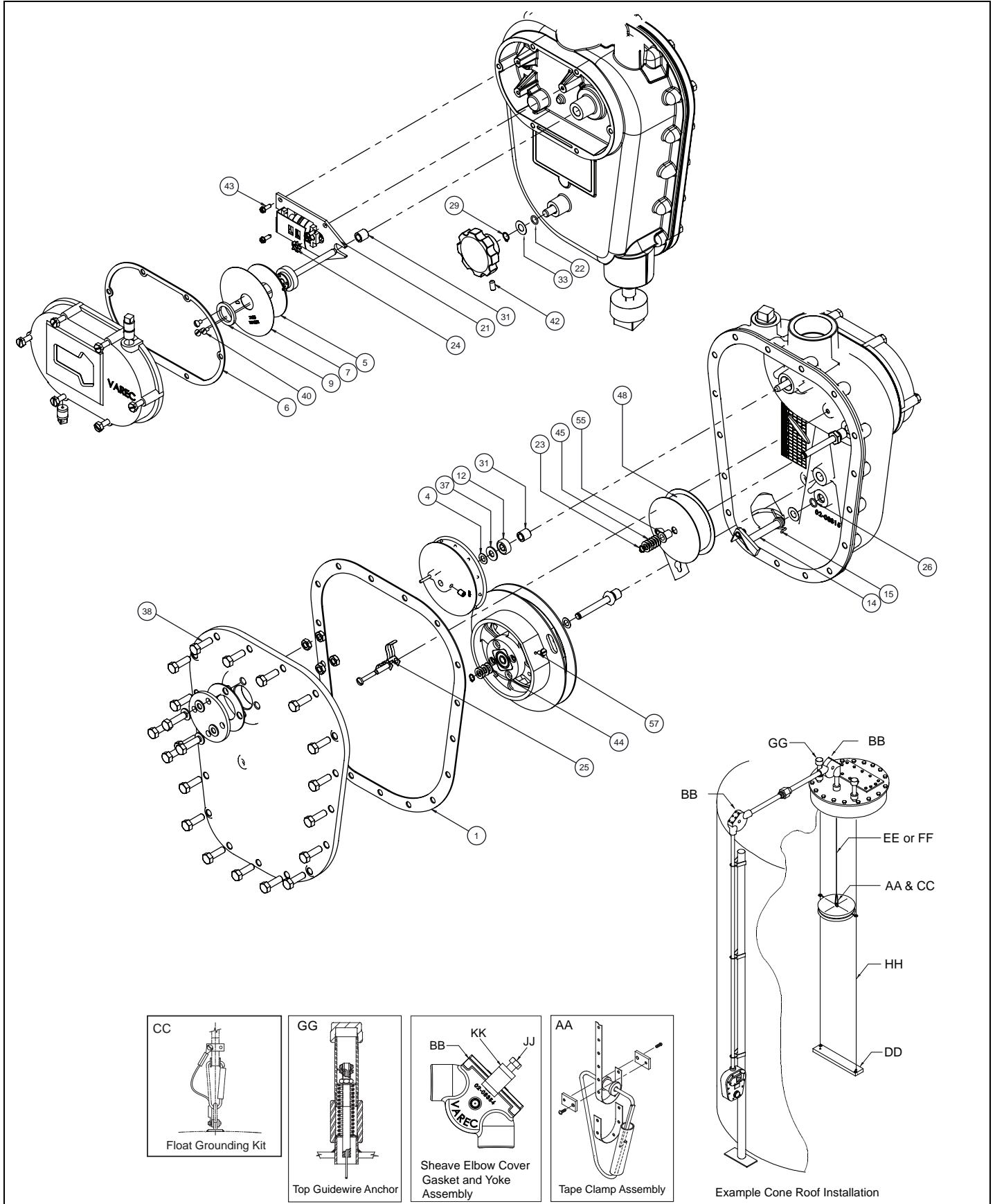

Figure 8-9: 2500 ATG (Type C Gauge Head Shown) Overhaul Maintenance Kit Parts Diagram

Additional items

When performing a complete overhaul or refurbish, Varec recommends replacement of the tape (or tape and cable combination), anchors, and guide wires as shown in the following table.

| Item | Part No. | Description |
|------|------------|--|
| AA | BM5478-600 | Tape Clamp Assembly |
| BB | A371-046 | Cover Gasket Sheave Elbow |
| JJ | P31-150 | Elbow Bolt |
| KK | A370-006 | Elbow Yoke |
| EE | B7650-606 | Tape - Imperial (Length 136'), (316 SS) for a tank 60 ft high |
| | B7650-306 | Tape - Imperial (Length 80'), (316 SS) for a tank 32 ft high |
| | B9736-606 | Tape - Metric (Length 41.25 m), (316 SS) for a tank 18.29 m high |
| | B9736-306 | Tape - Metric (Length 24.38 m), (316 SS) for a tank 9.75 m high |
| FF | B7678-606 | Tape and Cable (\emptyset 3/32") Combination - Imperial (Length 133') for a tank 60 ft high |
| | B7678-306 | Tape and Cable (\emptyset 3/32") Combination - Imperial (Length 73') for a tank 30 ft high |
| | B13982-606 | Tape and Cable (\emptyset 3/32") Combination - Metric (length 44.5 m) for a tank 18 m high |
| | B7678-106 | Tape and Cable (\emptyset 3/32") Combination - Imperial (Length 73') for a tank 30 ft high |
| | B13982-606 | Tape and Cable (\emptyset 3/32") Combination - Metric (Length 22.2 m) for a tank 9 m high |
| GG | BM5200 | Top Anchor - welded (Steel) |
| | BM5088 | Top Anchor - welded (316 SS) |
| | BM3603 | Top Anchor - bolted (Steel) |
| HH | B10543-306 | Guide Wire Tank Height 32 ft. |
| | B10543-606 | Guide Wire Tank Height 60 ft. |

Table 8-6: Additional Items Recommended for Tank Overhaul List

Shoulder Bushing Retrofit Kit

The Shoulder Bushing Retrofit Kit provides the parts required to replace the shoulder bushings on the 2500 ATG.

| Part No. | Description | | |
|-------------|-------------------------------|------------------|-----|
| 13-09794-00 | Shoulder Bushing Retrofit Kit | | |
| Item | Part# | Description | QTY |
| 23 | P10-2 | Retaining Ring | 4 |
| 44 | P31-1 | Washer | 2 |
| 45 | P31-13 | Shim Washer | 6 |
| 55 | O2-09598 | Shoulder Bushing | 4 |
| 56 | B14872-101 | Motor Top Plate | 1 |
| 72 | P013-29-1883 | Slotted Shim | 1 |

Table 8-7: Shoulder Busing Kit and Individual Parts List

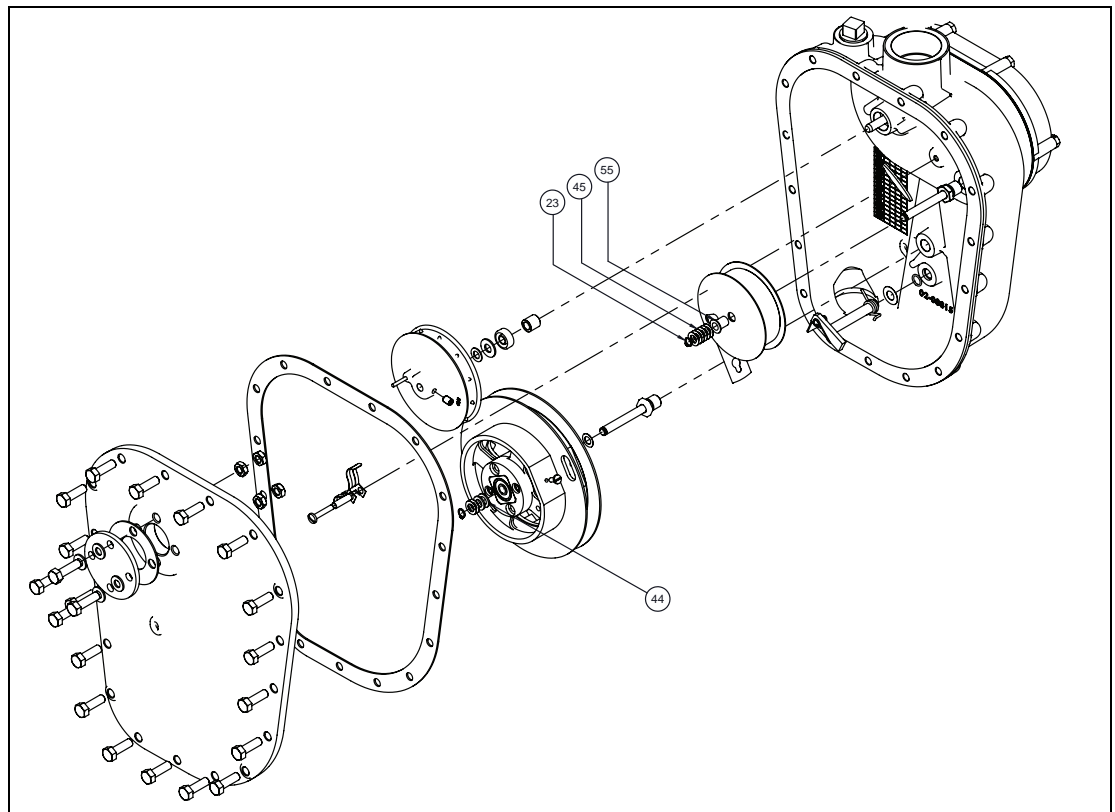

Figure 8-10: 2500 ATG (Type C Gauge Head Shown) Shoulder Bushing Retrofit Kit Parts Diagram

Elbow Maintenance Kits

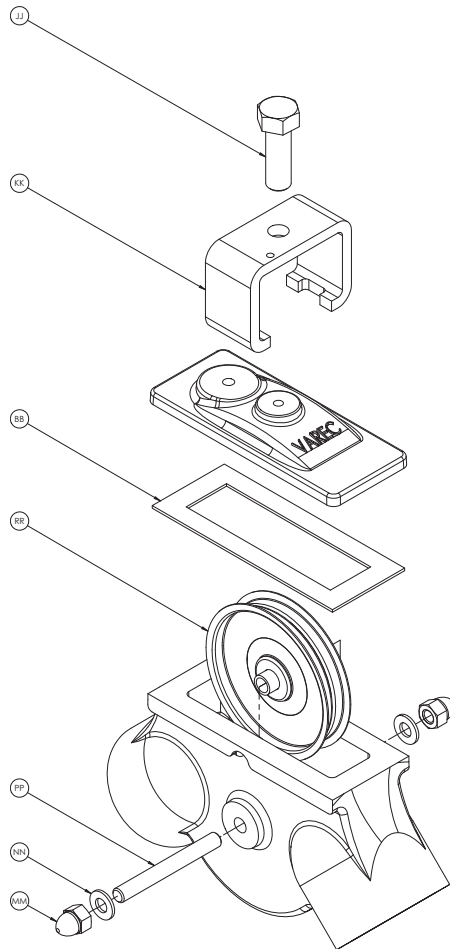

Figure 8-11: Elbow Kit Exploded View

The Elbow Maintenance Kits provide the parts required to rebuild the sheave elbow on the 2500 ATG.

| Part | Description |
|------------|--|
| BM4547 | Delrin Sheave Rebuild Kit (2x MM, 2x NN, 1 PP (303SS), 1x RR (Delrin)) |
| 13-07526 | SS Sheave Rebuild Kit (2x MM, 2x NN, 1x PP (316SS), 1x RR (316SS)) |
| 13-08560 | Elbow Rebuild Kit, Delrin Sheave (1x BM4547, 1x BB, 1x JJ, 1x KK) |
| 13-08560SS | Elbow Rebuild Kit, SS Sheave (1x 13-07526, 1x BB, 1x JJ, 1x KK) |

| Item | Part# | Description |
|------|--------------|---------------------|
| MM | P031-14-1576 | Acorn Nut (SS) |
| NN | P031-32-1661 | Fiber Washer |
| PP | B6674-033 | Elbow Shaft (303SS) |
| | B6674-006 | Elbow Shaft (316SS) |

| Item | Part# | Description |
|------|--------------|---------------------------|
| RR | 02-04981-044 | Elbow Sheave (Delrin) |
| | BA6696 | Elbow Sheave (316SS/PTFE) |

Negator Cassette and Negator Cassette Kit

The Negator Cassette Kit (part number 13-10652) provides the parts required to convert a 2500 ATG fitted with a negator motor to a gauge head with a negator cassette.

| Item | Part# | Description | QTY |
|------|----------|---------------------------------|-----|
| 50 | 06-10368 | Negator Cassette only | na |
| | 13-10652 | Negator Cassette Conversion Kit | na |

Table 8-8: Negator Cassette Kit and Individual Parts List

The Negator Cassette Conversion Kit (13-10652) has the following parts:

| Item | Part# | Description | QTY |
|------|--------------|---|-----|
| 4 | B7415-093 | Teflon Washer (Not shown - as used on older models) | 2 |
| 23 | P10-2 | Retaining Ring, 5/16 SS | 1 |
| 44 | P31-1 | Washer 9/16X21/64X1/16 SS. | 1 |
| 45 | P31-13 | Shim washer .562X.316/.313X.005SS | 6 |
| 49 | P031-11-1807 | HSCS 1/4-20X1-1/4 | 2 |
| 50 | 06-10368 | Negator Cassette | 1 |
| 51 | 06-10364 | Tape Storage Sheave Assembly - Cassette | 1 |
| 52 | 06-10490 | Crank Handle Assy - Cassette | 1 |

Table 8-9: Negator Cassette Conversion Kit components

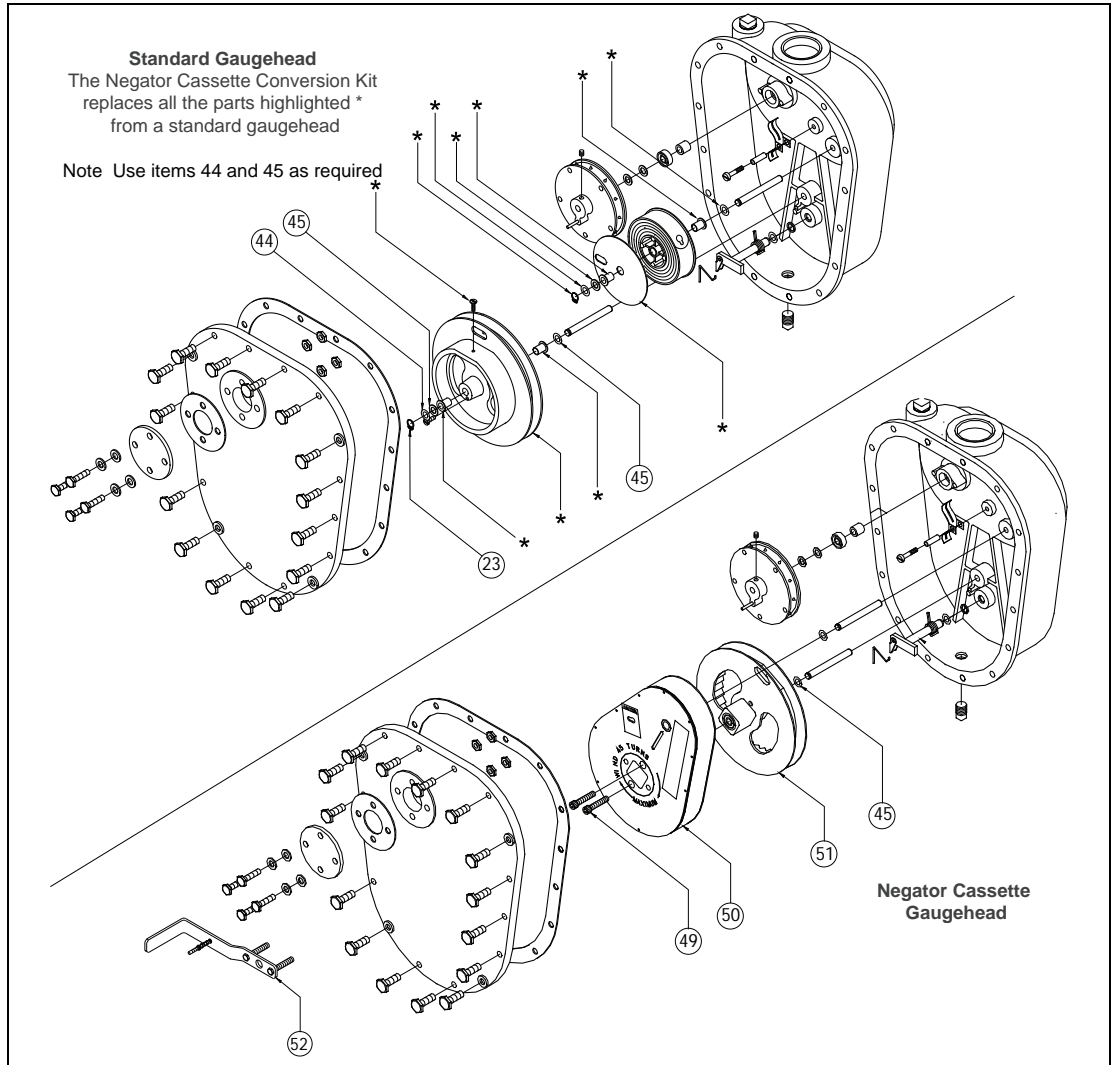

Figure 8-12: 2500 ATG (Type B Gauge Head Shown) Negator Cassette Conversion Kit Parts Diagram (Item 68)

Float Grounding Kit

The Float Grounding Kit positively grounds the float to the tape or cable. Connect the grounding cable (A) to the tape clamp (point B) and float (point C) as shown in Figure 8-13.

| Item | Part # | Description | Qty |
|------|--------------|---|-----|
| | 13-10974-006 | Float Grounding Kit (Float and Tape Clamps and Grounding Cable) | 1 |

Table 8-10: Float Grounding Kit List

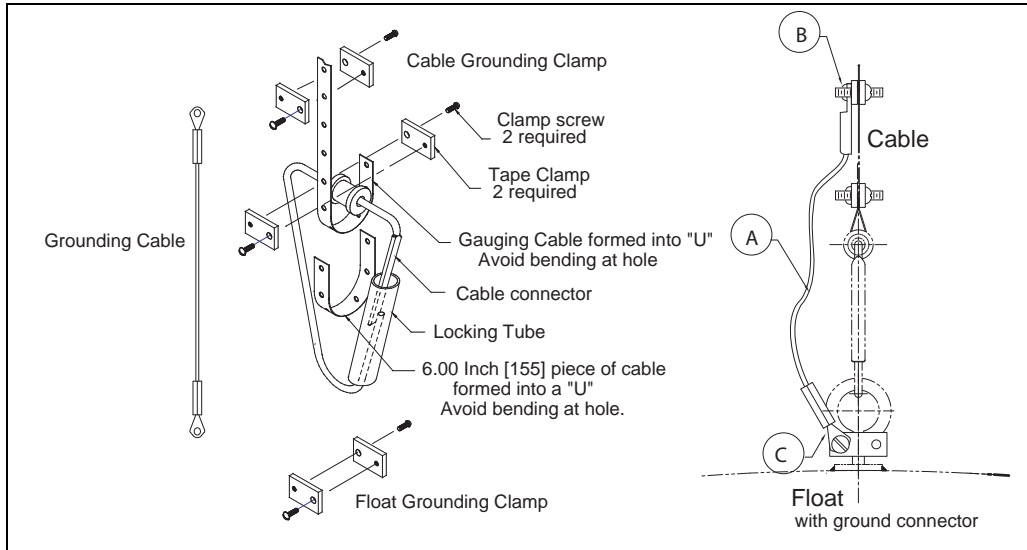

Figure 8-13: Float Grounding Kit Diagram

Other Accessories

Condensate Reservoir

The condensate reservoir is designed to collect condensate that would otherwise accumulate in the gauge head. Its use is recommended where an excessive amount of condensate could develop or in oil filled gauge applications (Part #DA4051).

Figure 8-14: Condensate Reservoir

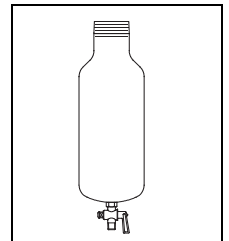

Shock Absorber

The Shock Absorber reduces wear and maintenance on a 2500 ATG by minimizing the transfer of wave energy from the float to the perforated tape and gauge head components. It prevents the float from becoming detached from the tape by wave action and should always be used in tanks with turbulent conditions near inlet or outlet piping and near a mixer (Part #DA6138).

Figure 8-15: Shock Absorber

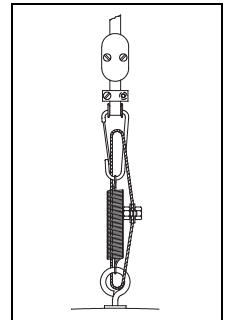

Floating Roof Anchor Weight

The Floating Roof Anchor Weight rests on the floating roof pan, but is not attached to the pan. This allows rapid movement of the floating pan without over-stressing the 2500's cable.

Caution! The floating roof must be reinforced under the anchor weight.

Figure 8-16: Floating Roof Anchor Weight

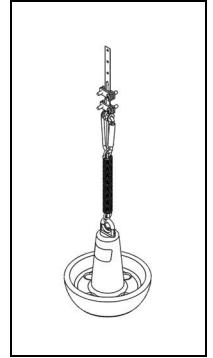

Part Numbers for Complete Gauge Heads Spare Parts

| Part # | Description |
|----------------|--|
| 10-10712-01 | Gauge Assembly, 2500 English w/Negator Cassette |
| 10-10712-02 | Gauge Assembly, 2500 Metric w/Negator Cassette |
| BM13661-111 | Alum-English w/Check Knob |
| BM13661-111EXT | Alum-English w/Check Knob, Extended Range |
| BM13661-111OUT | Alum-English w/Check Knob - Outage |
| BM13661-211 | Cast Iron-English w/Check Knob |
| BM14514-110 | Alum-Metric w/Check Knob |
| BM14514-110EXT | Alum-Metric w/Check Knob, Extended Range |
| BM14514-110OUT | Alum-Metric w/Check Knob, Outage |
| BM14514-210 | Cast Iron-Metric w/Check Knob |
| BM18909-111 | Alum-English w/Crank |
| BM18909-111EXT | Alum-English w/Crank, Extended Range |
| BM18910-110 | Alum-Metric w/Crank |
| BM18910-110EXT | Alum-Metric w/Crank, Extended Range |
| 10-10712-01OUT | Gauge Assembly, 2500 English w/Negator Cassette - Outage |
| 10-10712-02OUT | Gauge Assembly, 2500 Metric w/Negator Cassette - Outage |

Table 8-11: Part Numbers for Complete 2500 ATG Gauge Heads Spare Parts List

9 Troubleshooting

Friction is a common problem that affects gauge accuracy. Some liquids produce corrosion in the mechanism. Periodic inspection and maintenance provided by a Varec service contract can prevent problems from occurring. Periodic cleaning, lubrication, and replacement of worn parts stops trouble before it starts.

Dials Do Not Respond When Gauge Check Knob is Rotated

Caution! Broken negator spring may cause injury. Stand clear of gauge head when removing back cover.

| Possible Cause | | Action |
|----------------|--|---|
| 1 | Tape broken? | Yes - <ul style="list-style-type: none"> • Replace tape. • Check attachment of negator motor to storage sheave. • Check for damaged gauge parts. No - <ul style="list-style-type: none"> • Go to 2. |
| 2 | Negator motor broken? | Yes - <ul style="list-style-type: none"> • Replace negator. • Do not redrill or repair. • Wear gloves. • Check tape condition. • Check for damaged gauge parts. No - <ul style="list-style-type: none"> • Go to 3. |
| 3 | Tape rewound? | Yes - <ul style="list-style-type: none"> • Tape detached from float. • Replace tape and re-attach. • Check for damaged gauge parts. No - <ul style="list-style-type: none"> • Go to 4. |
| 4 | Dials stopped? | Yes - <ul style="list-style-type: none"> • Check for frozen tape sprocket sheave shaft. Repair/replace. • Check for frozen accessory shaft. Repair/replace. • Check dial gear engagement with pinion gear. Adjust/replace. • Check gauge checker for broken spring and damaged ratchet pawl. Replace. No - <ul style="list-style-type: none"> • Go to 5. |
| 5 | Counter dial wheels stopped; dial rotates? | Yes - <ul style="list-style-type: none"> • Check for worn/broken counter pinion gear and counter wheels. • Replace as necessary. |

Table 9-1: Broken Negator Spring - Possible Cause / Action

Calibration Repeatability Unstable

Caution! Broken negator spring may cause injury. Stand clear of gauge head when removing back cover.

| Possible Cause | | Action |
|----------------|---|---|
| 1 | Dirty gauge housing? | Yes - <ul style="list-style-type: none"> Clean with automotive-type spray degreaser. No - <ul style="list-style-type: none"> Go to 2. |
| 2 | Tape or cable off elbow pulley? | Remove elbow covers. Yes - <ul style="list-style-type: none"> Reseat and lubricate the gauge. No - <ul style="list-style-type: none"> Go to 3. |
| 3 | Elbow pulley shaft or bushing is worn or? | Yes - <ul style="list-style-type: none"> Repair or replace No - <ul style="list-style-type: none"> Go to 4. |
| 4 | Tape conduit dirty? | Yes - <ul style="list-style-type: none"> Remove and clean. No - <ul style="list-style-type: none"> Go to 5. |
| 5 | Guide cables loose, kinked or broken? | Yes - <ul style="list-style-type: none"> Tighten, repair or replace. No - <ul style="list-style-type: none"> Go to 6. |
| 6 | Worn Teflon bushings or bearings? | Yes - <ul style="list-style-type: none"> Refurbish gauge, replace Teflon bushings or bearings. Special tools may be required. |

Table 9-2: Broken Negator Spring - Possible Cause/ Action

10 Specifications and Reference Data

Device Designation/Nameplate

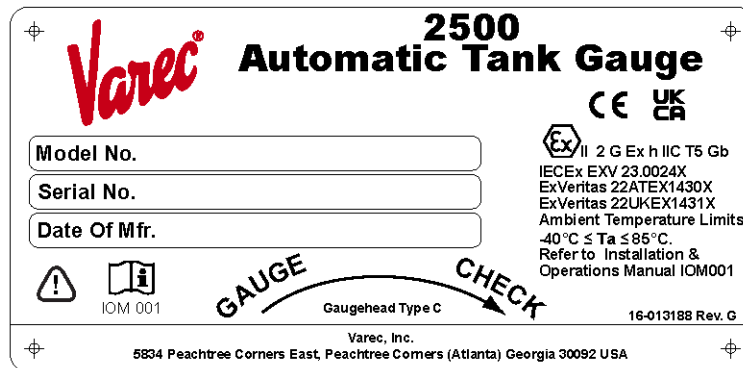

Figure 10-1: Nameplate for the 2500 ATG

CE Marks, Declaration of Conformity

The instrument is designed to meet state-of-the-art safety requirements, has been tested, and left the factory in a condition in which it is safe to operate. The instrument complies with the applicable standards and regulations in accordance with EN 13463-1 “Non-electrical equipment for use in potentially explosive atmospheres - Basic method and requirements”. The instrument described in this manual thus complies with the statutory requirements of the EC directives. Varec confirms the successful testing of the instrument by affixing to it the CE mark.

2500 ATG Gauge Head

| Description | Aluminum Gauge Head | Cast Iron Gauge Head |
|---|--|--|
| Gauge Head | Aluminum | Cast Iron |
| Counter housing & cover | Aluminum | Cast Iron housing Aluminum cover |
| Sprocket, Motor Storage and Tape storage sheaves | Cast aluminum | Cast Iron sprocket Mild steel motor storage hub with 304SS flange |
| Negator spring, Perforated tape and Sprocket Pins | Type 301 stainless steel Type 316 stainless steel Type 303 stainless steel | Type 301 stainless steel Type 316 stainless steel Type 303 stainless steel |
| Bearings | Stainless steel | Teflon |

Table 10-1: 2500 ATG Gauge Head Materials

2500 ATG Product Dimensions

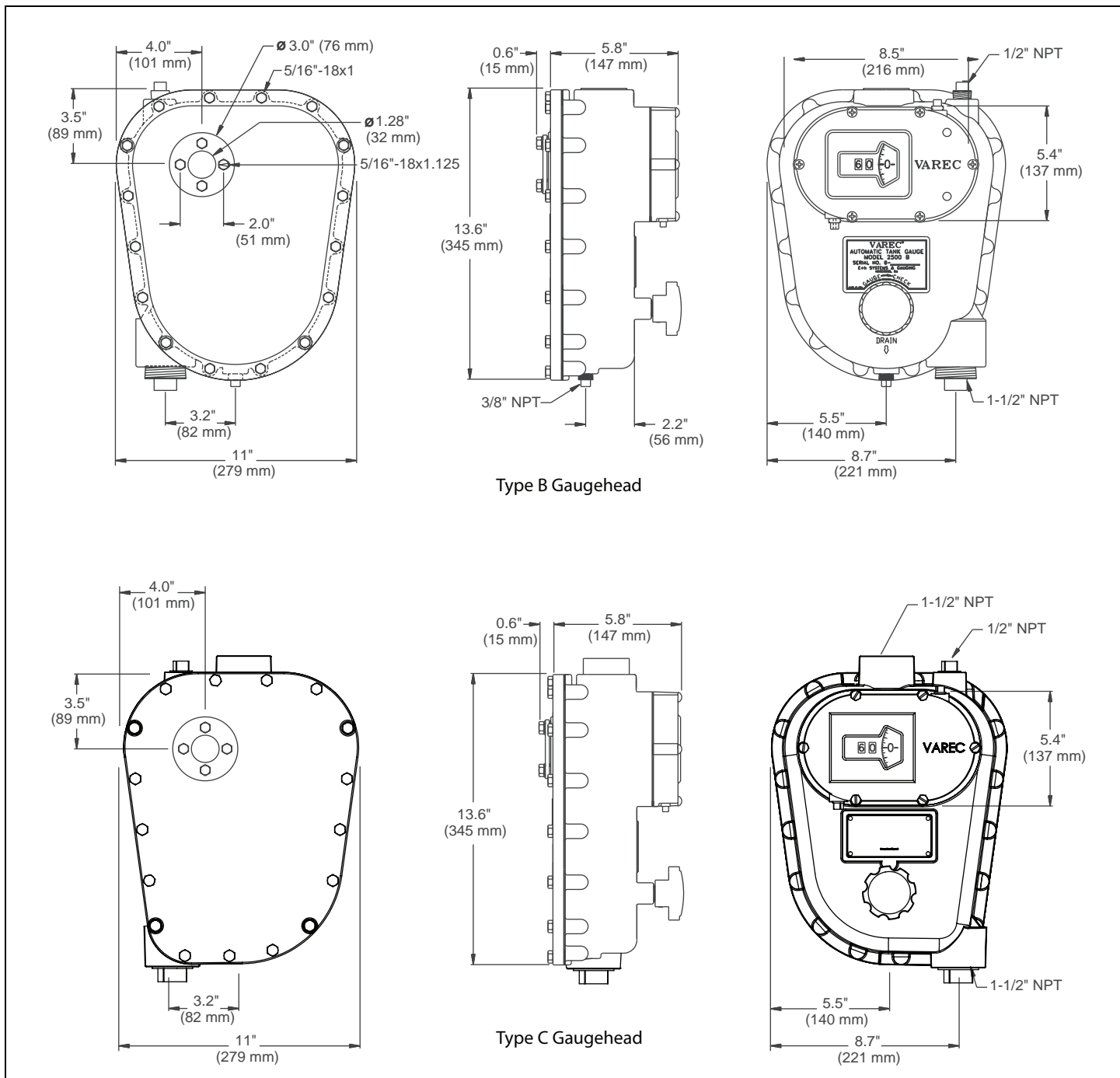

Figure 10-2: 2500 ATG Product Dimensions

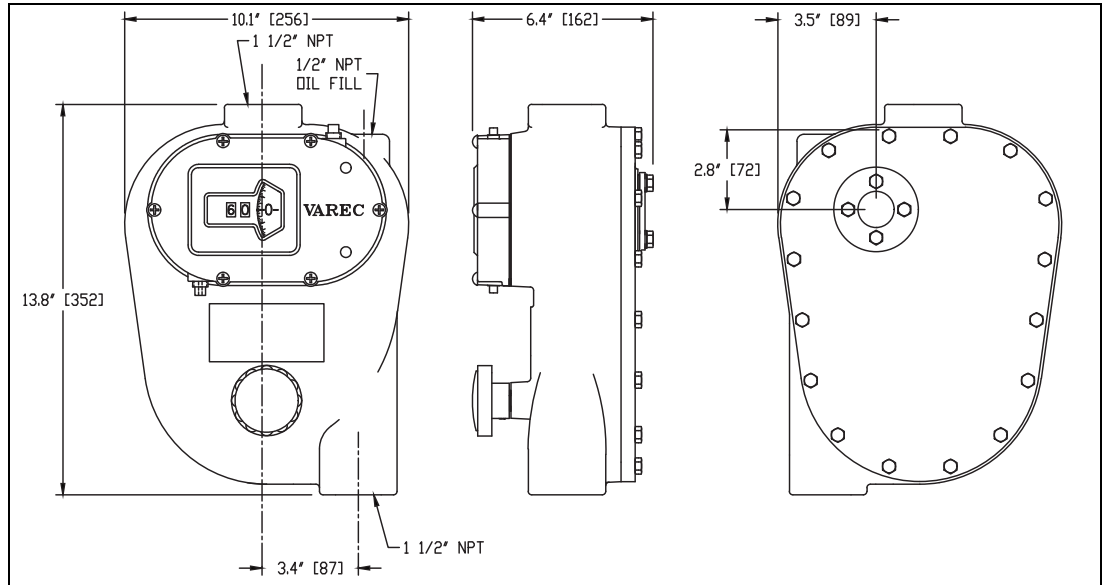

Figure 10-3: 2500 Cast Iron Gauge Head Product Dimensions

Floats

| Part # | Material | Net Weight | Size |
|-------------|-------------|--|---------------------------------|
| BM9074-000 | 316 S.S. | 8.8 lb (4 kg) | 17" (432 mm) Flat |
| BM12339-000 | Alloy 20 | 10.7 lb (4.9 kg) | 17" (432 mm) Flat |
| BM12338-000 | Monel | 10.5 lb (4.8 kg) | 17" (432 mm) Flat |
| BM12411 | 316 SS | 11 lb | 8" (203 mm) Multi-sphere |
| BM17777-006 | 316 SS | Depends on specific gravity of product - contact factory | 8" (203 mm) Sphere (interface) |
| BM17782-006 | 316 SS | | 6" (152 mm) Sphere (interface) |
| BM17783-006 | 316 SS | | 10" (254 mm) Sphere (interface) |
| P29-43 | Fiber glass | 9 lb | 17" (432 mm) Flat |

Table 10-2: Floats

Conduit Elbows

| Part # | Angle | Description | Pressure Rating | Conduit Material | Wheel Material |
|----------|-------|--------------|--------------------|---------------------|----------------|
| BM3661 | 90° | Elbow | 150 PSIG (1.1 MPa) | Cast iron | 316 SS |
| BM3491 | 90° | Elbow | 300 PSIG (2.2 MPa) | Cast iron | 316 SS |
| BM3490 | 45° | Elbow | 300 PSIG (2.2 MPa) | Cast iron | 316 SS |
| BM3489 | 30° | Elbow | 300 PSIG (2.2 MPa) | Cast iron | 316 SS |
| 06-08564 | 90° | Elbow | Atmospheric | Aluminum | Delrin |
| 06-07726 | 90° | Elbow | Atmospheric | Aluminum | 316 SS |
| BM4675 | 90° | Elbow | Atmospheric | Cast iron | 316 SS |
| BM5074 | 90° | Elbow | Atmospheric | 316 Stainless steel | 316 SS |
| BM3480 | 135° | Elbow | Atmospheric | Aluminum | Delrin |
| BM3481 | 180° | Elbow | Atmospheric | Aluminum | Delrin |
| BM3621 | NA | Tape carrier | Atmospheric | Aluminum | Delrin |

Table 10-3: Conduit Elbows

Standard Installation Kits

| Description | Standard | Moderate | Severe | Extreme (NaOH) | Extreme (H2SO4) |
|-------------------|----------|----------|-----------|----------------|-----------------|
| Gauge Head | Aluminum | Aluminum | Cast iron | Cast iron | Cast iron |
| Elbow assembly | Aluminum | 316 S.S. | Cast iron | Cast iron | Cast iron |
| Top anchors | Steel | 316 S.S. | Steel | Steel | Stl/Alloy 20 |
| Guide Wire weight | Steel | 316 S.S. | 316 S.S. | Monel | Alloy 20 |
| Guide Wires | 316 S.S. | 316 S.S. | 316 S.S. | Monel | Alloy 20 |
| Perforated tape | 316 S.S. | 316 S.S. | 316 S.S. | Monel | Alloy 20 |
| Standard float | 316 S.S. | 316 S.S. | 316 S.S. | Monel | Alloy 20 |

Table 10-4: Standard Installation Kits

Oil Seals

| Part # | Material | Oil seal |
|--------------|-----------|--|
| 10-01994-AAA | Aluminum | 8.5" (216mm) Water column operating pressure |
| 10-01994-BAA | Cast iron | 8.5" (216mm) Water column operating pressure |
| 10-02861-AAA | Aluminum | 27" (686mm) Water column operating pressure |

Table 10-5: Oil Seals

Approvals

| Item | Description |
|-----------------------------|--|
| Approval Type | ATEX EN ISO 80079-36 & 37 "Non-electrical equipment for use in potentially explosive atmospheres - Basic method and requirements" UKCA IEC60079-0 "Specifies the general requirements for construction, testing and marking of Ex Equipment and Ex Components intended for use in explosive atmospheres" |
| Approval Certificate Number | ATEX Certificate Number: ExVeritas 22ATEX1430X UKCA Certificate Number: ExVeritas 22UKEX1431X |
| Product Option Codes | N250001 – 2500 Automatic Tank Gauge, English, Negator Motor N250002 – 2500 Automatic Tank Gauge, English, Float Crank N250003 – 2500 Automatic Tank Gauge, Metric, Negator Motor N250004 – 2500 Automatic Tank Gauge, Metric, Float Crank N250005 – 2500 Automatic Tank Gauge, English, Iron Gauge Head N250006 – 2500 Automatic Tank Gauge, Metric, Iron Gauge Head N250011 – 2500 Automatic Tank Gauge, English, Negator Cassette N250013 – 2500 Automatic Tank Gauge, Metric, Negator Cassette |

Table 10-6: Approvals

Other Specifications

| Item | Material |
|---------------------|--|
| Service Rating | 2.5 psig (aluminum), 14.9 psig (cast iron) |
| Pipe Connections | 1 1/2 inch NPT |
| Maximum Tank Height | 60 feet (18.2 m), 90 feet (27.4m) for extended range |
| Shipping Weight | 70 lbs. (33 kg) (nominal; weight increases with various kits). |

Table 10-7: Other Specifications

11 Order Codes

Note

- For outage reading, please specify "OUT". For example N250001-T55 OUT. For outage versions with metric units, please contact the factory.
- For asphalt applications, please specify "AP". For example N250001-T55 AP.
- For an IP66 certified gauge, please specify "IP66". For example N250001-T55 IP66
- For an Iron Gaugehead for use in pressurized applications up to 10 PSI, please specify "PT". For example N250001-T55 PT.

Aluminum Gauge Head – English Configuration – Negator Motor

| 10 | Tank Type | |
|----------|-----------|---|
| | T01 | Standard service cone roof tank |
| | T02 | Standard service cone roof tank with pan and floatwell |
| | T03 | Standard service floating roof tank and floatwell |
| | T04 | Standard service tank top mounting |
| | T05 | Standard service bolted tank |
| | T06 | Standard service floating roof tank; no floatwell |
| | T07 | Standard service cone roof tank and pan; no floatwell |
| | T41 | Moderate service cone roof tank |
| | T51 | Interface service cone roof tank; 15 min. s.g. differential |
| | T52 | Interface service cone roof tank; 25 min. s.g. differential |
| | T55 | Stilling well service cone roof tank; 6" dia. float |
| N250001- | | Complete product designation |

Aluminum Gauge Head – Metric Configuration – Negator Motor

| 10 | Tank Type | |
|----------|-----------|---|
| | T11 | Standard service cone roof tank |
| | T12 | Standard service cone roof tank with pan and floatwell |
| | T13 | Standard service floating roof tank and floatwell |
| | T14 | Standard service tank top mounting |
| | T15 | Standard service bolted tank |
| | T16 | Standard service floating roof tank; no floatwell |
| | T17 | Standard service cone roof tank and pan; no floatwell |
| | T42 | Moderate service cone roof tank |
| | T53 | Interface service cone roof tank; 15 min. s.g. differential |
| | T54 | Interface service cone roof tank; 25 min. s.g. differential |
| | T56 | Stilling well service cone roof tank; 6" dia. float |
| N250003- | | Complete product designation |

Aluminum Gauge Head – English Configuration – Float Crank

| 10 | Tank Type | |
|----------|-----------|---------------------------------|
| | T01 | Standard service cone roof tank |
| | T05 | Standard service bolted |
| N250002- | | Complete product designation |

Aluminum Gauge Head – Metric Configuration – Float Crank

| 10 | Tank Type | |
|----------|-----------|---------------------------------|
| | T11 | Standard service cone roof tank |
| N250004- | | Complete product designation |

Iron Gauge Head – English Configuration

| 10 | Tank Type | |
|----------|-----------|---------------------------------------|
| | T21 | Standard service cone roof tank SS316 |
| | T22 | Extreme service cone roof tank; monel |
| | T24 | Severe service tank top mounting |
| N250005- | | Complete product designation |

Iron Gauge Head – Metric Configuration

| 10 | Tank Type | |
|----------|-----------|---------------------------------------|
| | T31 | Standard service cone roof tank |
| | T32 | Severe service tank top mounting |
| | T33 | Extreme service cone roof tank; monel |
| N250006- | | Complete product designation |

Aluminum Gauge Head – English Configuration – Negator Cassette

| 10 | Tank Type | |
|----------|-----------|--|
| | T01 | Standard service cone roof tank |
| | T02 | Standard service cone roof tank with pan and floatwell |
| | T03 | Standard service floating roof tank and floatwell |
| | T04 | Standard service tank top mounting |
| | T05 | Standard service bolted tank |
| | T06 | Standard service floating roof tank; no floatwell |
| | T07 | Standard service cone roof tank and pan; no floatwell |
| | T41 | Moderate service cone roof tank |
| | T55 | Stilling well service cone roof tank |
| N250011- | | Complete product designation |

Aluminum Gauge Head – Metric Configuration – Negator Cassette

| 10 | Tank Type | |
|----------|-----------|--|
| | T11 | Standard service cone roof tank |
| | T12 | Standard service cone roof tank with pan and floatwell |
| | T13 | Standard service floating roof tank and floatwell |
| | T14 | Standard service tank top mounting |
| | T15 | Standard service bolted tank |
| | T16 | Standard service floating roof tank; no floatwell |
| | T17 | Standard service cone roof tank and pan; no floatwell |
| | T42 | Moderate service cone roof tank |
| | T56 | Stilling well service cone roof tank |
| N250013- | | Complete product designation |

